

Soft Magnetics Application Guide



Introduction 30.3

Basics of Magnetics 30.4 – 30.11

- 1. Energy 30.4
- 2. Units of Measure 30.4
- 3. Simple Magnetic Theory 30.4
- 4. Permeability 30.5, 6
- 5. Saturation 30.6
- 6. BH (or Hysteresis) Loop 30.6, 7
- 7. Magnetic Energy 30.7, 8
- 8. Magnetic Circuits 30.8, 9
- 9. Electrical Properties of Magnetic Circuits 30.9
- 10. Soft Magnetic Materials 30.10
 - Core Loss 30.10
 - Energy Storage vs. Energy Transfer 30.10, 11

**Applications and Descriptions
of Arnold Product Lines 30.12 – 30.24**

- 1. Description of Applications 30.12, 13
- 2. Types of Materials 30.13 – 30.24
 - Soft Ferrite 30.13, 14
 - Scrapless Laminates 30.14
 - Powdered Iron 30.14, 15
 - MPP 30.16, 17
 - HI-FLUX™ 30.17
 - SUPER-MSS™ (Sendust) 30.18
 - Toroidal Tape Cores 30.18 – 30.22
 - Cut Tape Cores 30.22, 23
 - Bobbin Tape Wound Cores 30.23
 - Silectron Toroids 30.24
 - Silectron C and E Cores 30.24
 - Distributed Gap Cores 30.24

**Industry Applications of
Arnold Core Products 30.25, 26**

- 1. Frequency and Application 30.25
- 2. Low-frequency Applications 30.25
 - Power Conversion (Transformers) 30.25
 - Power Storage (Inductors) 30.25
- 3. High-frequency Applications 30.25, 26
 - Filters 30.25
 - Mag Amps and Saturable Reactors 30.25
 - Transformers 30.25, 26
- 4. Major Industry Groups 30.26

Appendix

- Recommended Application Charts 30.27 – 30.35

Magnetism...

The earth itself has magnetism. Ages ago, seagoing navigators learned how to use this phenomenon to sail their ships accurately from one port to another.

All of us are aware that the earth spins on an axis, the opposite ends of which have been designated as the geographic north and south poles. These geographic poles are near the earth's magnetic poles.

Invisible magnetic lines of force completely surround the earth. Oversimplified (but adequate for this discussion), these lines enter the earth at one pole, pass through the earth, exit at the other pole, and then loop back to the first pole. They are useful not only to the mariner on the high seas but also to the airplane pilot aloft.

Ancient mariners learned that certain substances, known as lodestones, would always point approximately north or south when suspended on a string. If the lodestone was deliberately moved from this position, it would slowly return to its original orientation. This gave evidence of a strange force which man could use.

Long after the mariner's compass became a universally useful navigational instrument, other pioneering scientists observed that a voltage could be measured between the ends of a piece of wire moved across magnetic lines of force. They also learned that, if the ends of a long enough wire were touched together, a tiny spark could be seen when the wire was moved very rapidly. Gradually, as these phenomenon were observed by scientists and word of their observations was circulated, the relationship between electricity and magnetism was discovered.

Although they did not understand the causes at first, they eventually developed the idea that something was flowing in the wire. In due course, new words such as voltage, current, resistance, and impedance began to creep into the strange, new jargon of science. Each new discovery added to the previous knowledge and, through such evolution, order developed out of conflicting opinions. That process continues today, although the points of discussion and discovery are now many times more specific in nature than the general concepts developed in the past.

Virtually everyone has an intuitive understanding of simple magnetic devices like the lodestone. However, an individual designing today's sophisticated magnetic products for the commercial market place must have a deeper knowledge and understanding of the subject.

The following training document provides some of the information and understanding needed to use magnetic products successfully. You'll find general information on magnetic theory and specific information on magnetic core types and applications. It requires a modest understanding of electrical circuits and basic principles of electronics, so some preparatory study would be beneficial for anyone without such background.

There are many ways to get up to speed in this subject. The possibilities include a basic electronics course of study or one of the programmed learning packages on the market. For example, the Heath Company offers a variety of electronics educational products.

Energy

Arnold serves industries and individuals deeply involved with conversion and utilization of magnetic energy. Their actual final products can range anywhere from computers to electrical power distribution to automobiles. This manual provides an understanding of the basic phenomenon of magnetics and how Arnold products allow it to be put to practical use.

Any energy form—be it electrical, thermal, chemical, or mechanical—is only of value to us if it can be used in our everyday life. This is called doing work. To do work for us, energy must be converted from one form to another. The products that Arnold manufactures facilitate this conversion and make it efficient enough to be of practical use. It is certainly possible to make permanent magnet (PM) motors with lodestone motor arcs and transformers from cut-up tin cans. But, how efficient would they be, and would they allow the design of the everyday electromagnetic devices that have become necessities to us?

Understanding the formation and utilization of energy is very important.

Units of Measurement

Before getting too involved in a discussion of magnetics, you should spend some time on one of the most controversial subjects you will encounter: the system of units that information/literature/design documentation should be using. Arnold Engineering has traditionally used the CGS (centimeter-gram-second) system. Its principal advantages are that the units are nicely “sized” for real-world magnetic materials, and that the permeability of free space is equal to one. (This last point will be defined more clearly later in this document.)

Unfortunately, CGS units receive only passing mention in formal training in electromagnetic theory. The system of choice in academic and scientific communities is the MKS (meter-kilogram-second) system or, as it is often called, the SI (System International) system. These units tend to be a little more awkward in size, and the permeability of free space is an exponential number. On the other hand, mathematical operations are much simpler when going from energy to power to flux density, etc.

Simple Magnetic Theory

Fundamental to all magnetic theory is the concept that a magnetic field is produced when a current passes through a conductor. The direction and intensity of this magnetic field is a function of the direction and amplitude of the current.

The simple circuit shown in Figure 1 depicts how electrical energy is converted to magnetic energy. A current source, in this case a battery, is attached to a length of conducting wire. Because the electrical circuit is closed, current flows. This current is called the excitation current and, when used with a certain coil geometry, results in what is referred to as the **Magnetizing Force**, or **MMF per unit length**, or the **H** of the coil. The unit of the measure is **Oersted** in CGS

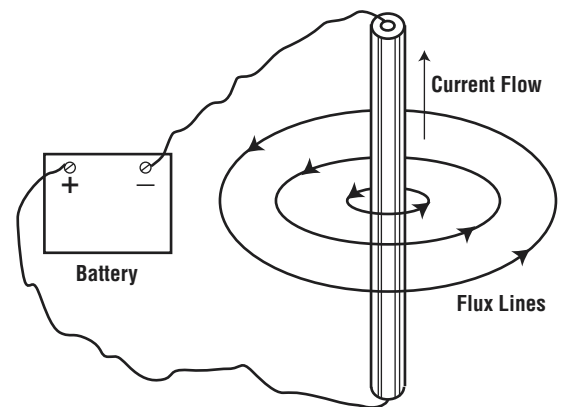

Fig. 1

units and **AMP-turn per meter** in SI units. Units of MMF (magneto-motive force) are **Gilbert** in CGS and **AMP-turn** in SI systems.

$$1 \text{ AMP-TURN per METER} = .0125 \text{ OERSTED}$$

The flow of current creates a “force field” that is concentric to the conductor. This field was arbitrarily called a magnetic field by 19th century researchers, and a measure of its magnitude was called **Flux**, or lines of flux, or **B**. In other words, some amount of amps of current creates some amount of lines of flux. The resulting magnetic field is a pool of potential energy. The unit of flux is the **Weber** or the **Volt-second** in the SI system, and the **Maxwell** in CGS.

$$1 \text{ WEBER} = 1 \text{ VOLT-SECOND}$$

$$1 \text{ WEBER} = 10^8 \text{ MAXWELLS}$$

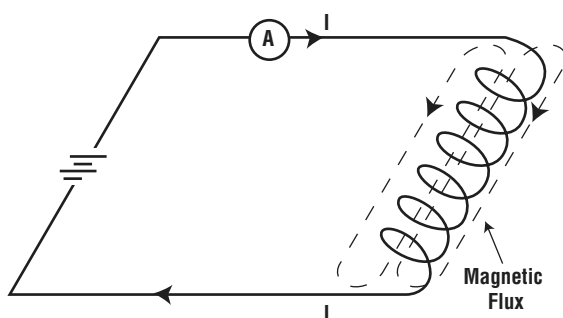

Fig. 2 Schematic representation of magnetic flux resulting from current flow in a coil.

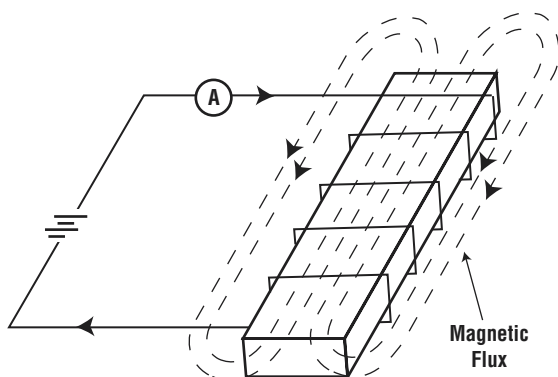

Fig. 3 Schematic representation of increased magnetic flux with a ferromagnetic core.

From this simple beginning, scientists manipulated the phenomenon to perform work more efficiently. The single loop of wire was made into a multiple-turn coil (see Figure 2), proportionately increasing the amount of lines of flux produced by a limited amount of current. Many times the only way early researchers had to measure the amount of flux produced by a certain configuration was to observe the amount of attractive force a coil exhibited. It was only a matter of time before someone came upon the idea of putting an iron “core” inside the coil conductors (see Figure 3) and, naturally enough, the amount of force produced increased drastically over all previous experiments.

Two important concepts began to evolve from this early research.

The first is that the presence of an iron “core” obviously increased the concentration of lines of flux within the coil of wire. This further solidified the notion of flux density, or the number of lines of flux per unit of cross-sectional area. Flux density is also sometimes referred to as induction. The unit of measure of flux density is **Gauss** in CGS units and

Tesla in SI units. Occasionally an engineer will use “lines per square inch” as a unit of induction, but this is not common.

$$1 \text{ TESLA} = 10,000 \text{ GAUSS}$$

$$1 \text{ TESLA} = 1 \text{ WEBER PER METER}^2$$

$$1 \text{ GAUSS} = 1 \text{ MAXWELL PER CM}^2$$

Flux density is one of the components used to determine the amount of magnetic energy stored in a given geometry. The other component is the MMF, described previously.

The other important concept that became apparent was that, in a situation where a magnetic material was inserted into a coil (see Figure 3), the flux (or flux density) was actually the result of two constituents—one being the contribution of the coil itself, the other the contribution of the iron core. These two parts are additive, and the total flux is the sum of the two.

$$\text{FLUX}_{\text{core}} + \text{FLUX}_{\text{coil}} = \text{FLUX}_{\text{total}}$$

The significance of this is best demonstrated by the use of normal and intrinsic demagnetization curves in Arnold’s permanent magnet literature. The intrinsic curve is representative of the magnet’s contribution, and the normal curve is the magnet plus the coil. There will be further discussion of this later in this document.

Permeability

Not all magnetic materials respond equally to the applied MMF. In other words, different materials exhibit different flux densities when subjected to the same magnetization levels. To account for this, scientists developed a term to describe the mathematical ratio of flux density to magnetizing force. This ratio, called **Permeability**, is a measure of the magnetic sensitivity of the material.

Every magnetic material has a permeability that is numerically greater than the value of the permeability of free space. This means that magnetic materials are more responsive to the applied MMF than the “air” that they occupy. Since the value of a magnetic material’s permeability is expressed relative to the permeability of free space, it will be numerically the same in either CGS or SI systems. The value of the permeability of free space, however, is quite different in the two systems.

Absolute permeability of free space = 1 (CGS) or $4\pi \times 10^{-7}$ (MKS)

The relative permeability of hard ferrite is slightly greater than 1

Relative permeability of neo-fe = slightly greater than 1

Relative permeability of samarium-co. = slightly greater than 1

Relative perm. of alnico = 3 - 7

" " " MPP = 14 - 350

" " " powdered iron = 8 - 75

" " " Silectron = up to 30,000

" " " Supermalloy = up to 300,000

Unfortunately, the permeability of magnetic materials is not constant. It is observed that permeabilities will change over a several-decade range as the excitation level is varied. Also, real-world materials are affected by their environment, and things like temperature and mechanical shock can have a profound effect on the actual value of permeability.

Saturation

Although magnetic materials are more susceptible to excitation than air, they have the drawback of limited flux capacity. As the applied excitation becomes higher and higher, the material reaches a point where its permeability approaches the permeability of free space and it cannot hold any more magnetic energy. This point is referred to as **Saturation** and is characterized by the material's **Saturation Flux Density**.

Saturation is strictly a material property; it is not a function of the excitation current. Many engineers tend to be misguided on this point. A material's saturation flux density is only a result of its metallurgy and its operating temperature. (However, the excitation level at which this saturation occurs is a function of just about everything.)

Most materials do not have a well-defined saturation flux density. If an engineer specifies that a material have a minimum saturation flux density, he should also specify at what excitation level this flux density is to be measured. There are no hard and fast rules as to where a material is, by definition, saturated.

BH Loop

In order to differentiate the properties of specific materials more easily, a measurement technique was devised that clearly shows all the phenomenon

described above. This is the hysteresisgram, or as it is more commonly called, the **Hysteresis Loop** or **BH Loop**. Since it is of such basic importance to magnetic designers, some explanation of its features will be given.

The BH loop is obtained by exciting the magnetic material sample with a controlled, and varied, MMF and simultaneously recording the resulting flux density induced in the sample. Generally the format is to excite the sample to saturation in the positive direction and then instantaneously reverse direction and excite it in the negative direction. The final step is to reverse direction again and return to the positive saturation point.

The sample may or may not be driven into saturation during the test sequence. This point is of particular significance in permanent magnets, where the full potential of a material can only be realized if it is completely saturated when magnetized. As a practical footnote, it should be mentioned that, in the case of all permanent magnet materials and a few soft magnetic materials, the excitation source is actually an electromagnet where the amp-turns are indirectly applied to the sample.

Figure 4 shows a typical BH or hysteresis loop. Flux density, B, is displayed on the vertical axis and magnetizing force, H, is on the horizontal axis. Note that positive and negative values of both parameters are utilized. One variation of the BH loop is the demagnetization curve commonly used to display the properties of permanent magnet materials. The "demag" curve only represents the second quadrant of the full BH loop. This is where the material has been magnetized and now a gradual demagnetizing MMF is being applied (and thus the term demag).

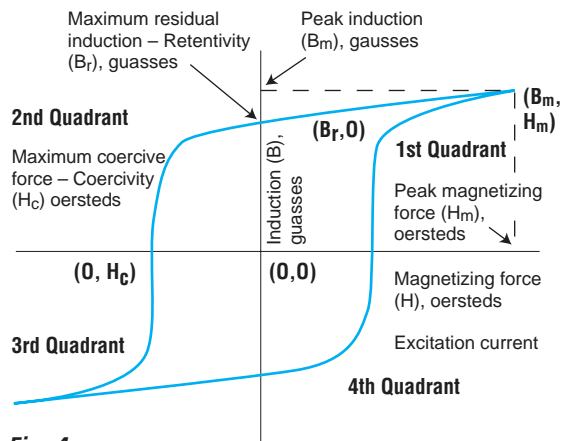

Fig. 4

For accurate results, the magnetic material sample being measured should start out completely demagnetized. This would be the axis point (0,0) on the BH loop in Figure 4. At that point the excitation current is zero and the sample contains no flux. As excitation is increased slowly in the positive direction, flux builds up in the material, also in the positive direction. Generally, the excitation is increased until saturation occurs; but, since this is not always the case, we will assume in this discussion that the material is not saturated. (The occurrence of saturation does not change the following test sequence.) This point of maximum excitation is signified on Figure 4 by $(+B_m, +H_m)$, where $+B_m$ is the maximum flux density observed and $+H_m$ is the maximum MMF applied. Current then is slowly decreased to zero, to the point on the curve labeled $(+B_r, 0)$. But, as indicated in Figure 4, the flux does not return to zero. Instead flux density assumes what is called the residual flux of the sample. The symbol for **Residual Flux** is B_r .

One of the distinguishing characteristics of real-world magnetic materials is that they have "memory" of their previous excitation condition. This results in a "lag" in the response of the material when excitation is varied. The residual flux is a manifestation of this phenomenon. (It should be noted that **all** magnetic materials, including core products, have residual flux values.) This lag is referred to as **Hysteresis**, from which the name hysteresisgram or hysteresis loop is taken.

Now the excitation is increased in the negative direction, and a demagnetizing force is applied against the sample's inherent residual flux. Eventually the magnetic energy, in the form of flux, is forced out of the sample and the flux density returns to zero. This is point $(0, -H_c)$. The amount of negative MMF required to demagnetize a material from B_r is called the **Coercivity** of the sample material. Obviously, the coercive force is designated by H_c . The unit for coercivity is the same as that for magnetizing force, either amp-turn per meter or oersted.

This parameter differentiates "hard," or permanent, magnetic materials from "soft", or core type, materials. Soft magnetic materials are quite easily demagnetized. Hard magnetic materials are quite difficult to demagnetize, so they are able to retain the magnetic energy stored in them better. In either case, unless something comes along to demagnetize them, magnetic energy will be stored in magnetic materials indefinitely. More discussion on this point will follow in later sections.

The remainder of the BH loop is simply a mirror image of the first two quadrants. The sample is driven to $(-B_m, -H_m)$, then $(-B_r, 0)$ then $(0, +H_c)$ and finally back to $(+B_m, +H_m)$.

As mentioned earlier, the flux in the "air space" within the exciting coil does contribute to the total, or normal, flux observed or measured in the BH loop. Some hysteresisgraphs, as the instruments are called, are equipped to correct for this and display the intrinsic BH loop of the material. Other instruments do not. This additional flux contribution is only of significance in those situations (such as Arnox and Neo-Fe) where it takes a large MMF to magnetize and demagnetize the material, or for materials such as low-permeability powder cores where it takes a significant amount of MMF to saturate the material. This subject is dealt with only rarely in the case of soft magnetic products but, in PM literature, both the normal and intrinsic demagnetization curves usually are given for high-coercivity materials (see Figure 5). For intrinsic BH loops, an additional "i" subscript is added to all the defining parameters described above. In other words, H_{ci} is the intrinsic coercivity of the sample, whereas H_c is the normal coercivity. Both normal and intrinsic demagnetization curves are of significance to the PM circuit designer.

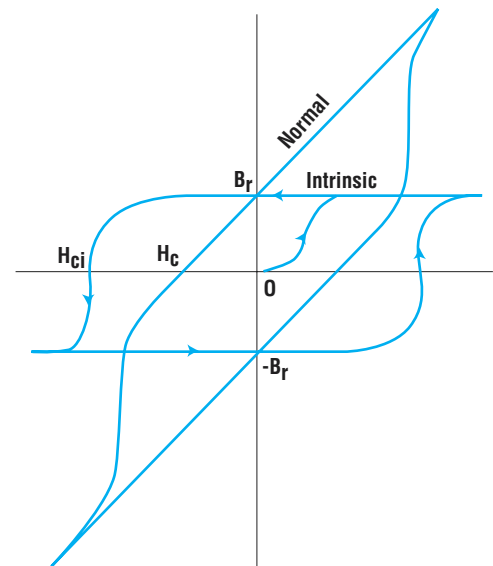

Fig. 5

Magnetic Energy

As originally stated, the intent and purpose of high-performance magnetic materials is to convert, store and utilize magnetic energy more efficiently.

By definition, magnetic energy is the product of the flux density in the magnetic circuit and the magnetizing force it took to excite the material to that flux level.

$$\text{Energy} = B \times H$$

The unit of energy in the SI system is the **Joule**, in the CGS system it is the **ERG**. In permanent magnet design a special energy density, or energy product, is also used to indicate energy and storage properties per unit volume. The CGS unit of energy product is the **Gauss-Oersted**. The SI unit is the **Joule Per Meter³**.

$$1 \text{ joule} = 10^7 \text{ ergs}$$

$$1 \text{ joule per meter}^3 = 125.63 \text{ gauss-oersted}$$

Now the differences between permanent magnets and core products start to become more apparent.

Soft magnetic materials, or core products, do have the ability to store magnetic energy that has been converted from electrical energy; but it is normally short-term in nature because of the ease with which these types of materials are demagnetized. This is desirable in electronic and electrical circuits where cores are normally used because it allows magnetic energy to be converted easily back into electrical energy and reintroduced to the electrical circuit.

Hard magnetic materials (PMs) are comparatively difficult to demagnetize, so the energy storage time frame should be quite long. The portion of the BH loop that shows the sample's normal state of energy storage is, as already described, the demagnetization portion of the curve from $(+B_r, 0)$ to $(0, -H_c)$.

If hard magnetic materials dissipated their stored energy back into the magnetizing electrical circuit quickly, as do soft materials, they would be of no value to us. Instead, they use this energy to establish a magnetic field external to the magnet itself. This external field does work for us by interacting with, for instance, the conductor current in a PM motor. Presumably, unless something causes it to become demagnetized, the permanent magnet will maintain this external field indefinitely. One of the common misconceptions of novice PM motor designers is that, somehow, the energy stored in the magnet is being consumed as the motor is operated normally. This is not true.

As explained before, the product of the flux density and the magnetizing force is a measure of the magnetic energy stored in the permanent magnet.

Magnetic Circuits

It is quite convenient to draw an analogy between the more common electrical circuit and something called a **Magnetic Circuit**. A magnetic circuit is essentially a schematic of the magnetic path, arranged in a closed loop, where the MMF sources (PMs and windings with applied currents) and MMF drops (areas with low permeability) are represented. To complete the analogy, "resistances" are against the applied MMF instead of the applied current, as is the case in the electrical circuit (see Figure 6).

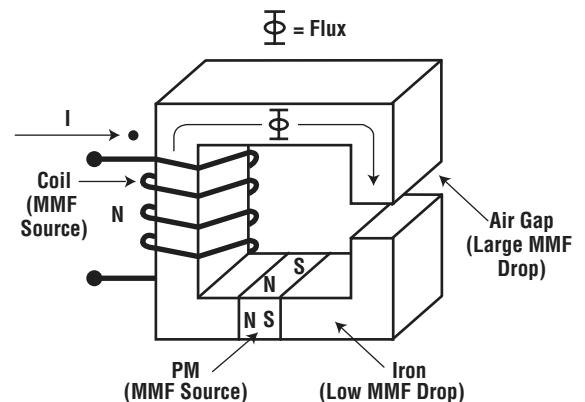

Fig. 6 Typical Magnetic Circuit

To facilitate the analysis of magnetic devices, the concept of **Reluctance** was introduced. This is the magnetic circuit "resistance" referred to above. This mathematical tool not only considers the permeability of that section of the magnetic circuit, but also its dimensions and shape.

The path that the lines of flux will take in a given geometry is analogous to current in an electrical circuit. Electrical current tends to take the path of least resistance. Magnetic flux tends to take the course of least resistance. Reluctance is inversely proportional to permeability and directly proportional to the length of the magnetic circuit.

Minimum reluctance is realized when the permeability of the magnetic materials are high, when the **Air Gap** in the magnetic path is reduced, and the configuration tends toward the material forming a closed loop (see Figure 7). In a PM circuit, the effect of reluctance is to demagnetize the material. Higher operating flux densities can be realized if the air gap (reluctance) in the PM circuit is reduced.

Generally, air gap is introduced into magnetic circuits in two ways: a **Discrete** air gap and a **Distributed** air gap (see Figures 8 and 9,

respectively). Discrete air gaps are significant in both PM and soft magnetic circuits; distributed air gap is only applicable to powder core products.

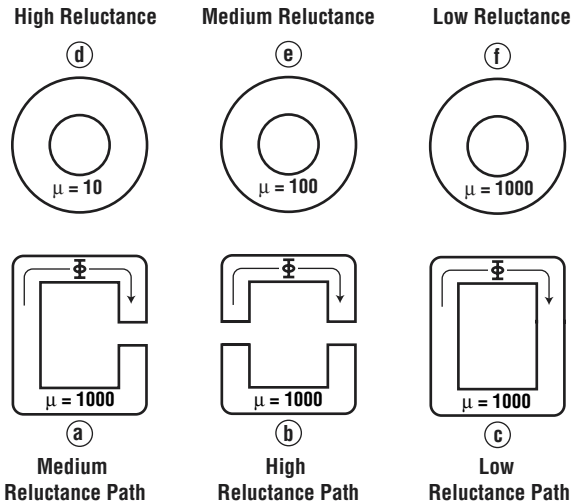

Fig. 7

A discrete air gap, as used in a gapped C-Core or in a PM motor, is best described by a situation where a very few (usually one or two) comparatively large air gaps are introduced into a basically high-permeability material that is part of the path of the circuit.

A distributed air gap actually refers to a very large number of small air gaps throughout the core. Examples of distributed air gap are Molybdenum Permalloy Powder (MPP) and powdered iron cores. Because it minimizes second-order effects such as leakage and fringing flux, distributed air gap allows the opportunity to obtain much larger effective air gaps in the magnetic path.

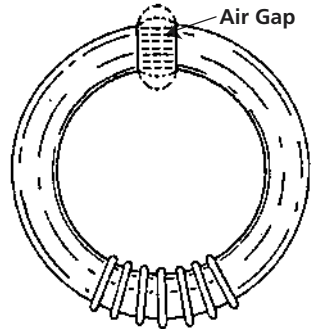

Fig. 8 Cutting a small section out of an iron ring to make an air gap increases the total reluctance and therefore reduces the total flux.

There are other ways to obtain an air gap without introducing a physical space into the circuit. One common occurrence is in a C-core where the normal manufacturing process (specifically the impregnation system) tends to lower the permeability of the material, creating an effective air gap. Additionally, dynamic effects such as core loss tend to create an effective air gap by reducing the net permeability of the material.

Electrical Properties of the Magnetic Circuit

Devices made with Arnold magnetic materials generally are used in conjunction with electrical current to perform useful work. This is almost always true of soft magnetic products and quite often true of hard magnetics as well (as in a PM motor, for instance). Whenever the device is connected to a circuit that provides current, it will exhibit certain electrical properties in that circuit. The most significant of these is **Inductance**.

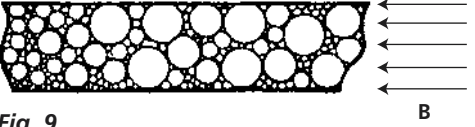

Fig. 9

Inductance, along with resistance and capacitance, is one of the three basic parameters of any electrical circuit. Inductance determines the electrical **Impedance** that the device presents to the electrical circuit. This, in turn, dictates the electrical current that will flow. The unit of inductance in both SI and CGS systems is the **Henry**. The unit of impedance in both systems is the **Ohm**.

Mathematically, inductance is inversely proportional to the reluctance of the magnetic circuit of the device. Thus a core with a large air gap (a high-reluctance magnetic circuit) will provide very little impedance to the electrical circuit. Likewise, a PM motor designed with a very large clearance between the rotor and the arc magnet will tend to provide less impedance to the circuit supplying the electrical power.

When a magnetic material saturates, permeability decreases and reluctance increases rapidly. Consequently, the impedance of that device tends toward zero and it begins to disappear from the electrical circuit.

Soft Magnetic Materials

Soft magnetic products (or core products, as they're more commonly called at Arnold) offered by Arnold consist of the **Molybdenum Permalloy Powder (MPP), HI-FLUX™ and SUPER-MSS™ cores**. In addition, a wide variety of tape wound products are available from National-Arnold Magnetics. Additional soft magnetic materials, in unfinished form, are sold through the Rolled Products Division of Arnold. Discussion will be restricted to finished cores in this document.

Core Loss

Core loss is of minimal importance in hard magnetic materials but is extremely important in soft magnetics. Core loss represents an inefficiency, so it is highly disdained by the designer. In many instances, core loss will render a particular material unusable in an application. The most glaring example would be the high-frequency power-conversion transformer industry, which is dominated by soft ferrites. In general, the products offered by Arnold are too lossy, however there are many important exceptions. For example, flyback transformers operated in a lower range of high switching frequency. Arnold powder core products are quite useful for high-frequency power conversion inductors. The reason for this will be explained in a later section. The unit of core loss in both SI and CGS systems is the **Watt**.

$$1 \text{ watt} = 1 \text{ joule per second}$$

Core loss is realized by two major components: **Hysteresis Loss** and **Eddy Current Loss**.

Hysteresis loss results from the fact that not all energy required to magnetize a material is recoverable when it is demagnetized. The wider and taller the hysteresis loop, the more hysteresis loss a material has.

Eddy current loss is the result of small circulating currents (eddy currents, not unlike eddy currents produced in the wake of a boat) that are induced when the flux density changes in the magnetic material (see Figure 10). The amplitude of these small currents is dependent on the **Electrical Resistivity** of the material. Products produced by Arnold have low resistivities. As a point of comparison, soft ferrites, while having large hysteresis losses, have very high resistivities and quite low eddy current losses. This is the reason they are the material of choice at high-frequency.

Energy Storage vs. Energy Transfer

As discussed previously, energy storage is a fundamental mechanism in magnetic theory. In soft magnetic materials this is exploited to introduce "time delay" into electrical currents. For instance, this time delay can be used to differentiate between frequencies or filter out unwanted frequencies in the excitation current. As a rule, cores used for this application require basic alterations to the magnetic circuit to enhance its energy storage.

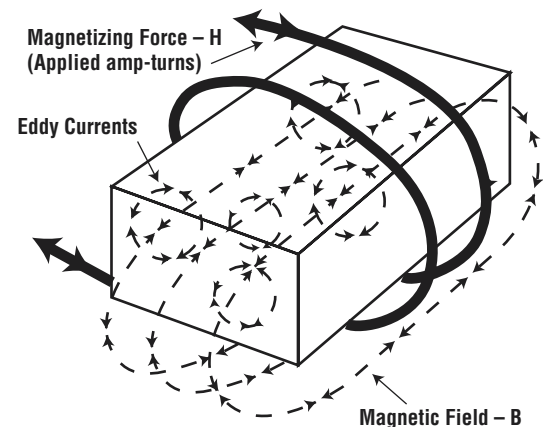

Fig. 10 Energy Loss in form of heat

The **Inductor** or the **Choke** explicitly utilizes the concept of storing electrical energy in the form of magnetic energy. The flux build-up in the core is proportional to the applied current and to the effective permeability of the core material. The magnetic energy is converted back into electrical energy as soon as the exciting current is removed.

It was stated previously that energy stored in a magnetic circuit (or core) is proportional to the applied excitation current multiplied by the resulting flux. Consequently, to increase the amount of energy stored in a given core (assuming that the basic dimensions don't change), there are only two possible alternatives: increase the flux or increase the applied amp-turns. Since all materials have an inherent and unchangeable saturation flux that limits the obtainable flux density, the only possibility is to somehow increase the applied current necessary to force the core into saturation: in other words, to "desensitize" the core to the magnetizing current. This is quite easy to accomplish simply by mechanically lowering the effective permeability (increasing the reluctance) of the device. This is almost always done by introducing an air gap into the magnetic circuit.

Energy Transfer is a special case of energy storage that is somewhat more difficult to understand than energy storage, which is basic to all magnetic devices.

Energy transfer in a magnetic device is most typically represented by a two-winding **Transformer**, where excitation current flows in one winding and an induced voltage appears in the other winding. At first glimpse, you might be tempted to say that no energy storage is taking place in a typical transformer. This is not the case. In fact, two energy conversion/storage mechanisms are taking place.

The first is the familiar “time delay” energy storage already described. This is generally undesirable in a transformer because it detracts

from the efficiency of the transfer. Usually every attempt is made to minimize exciting energy. The user wants maximum permeability in the core of a transformer, so air gap—either real or apparent—is minimized.

The desirable conversion/storage mechanism is where magnetic energy stored in the core is almost instantaneously transferred to the secondary winding and the electrical load attached to it. The core never really “sees” this magnetic energy, and the magnetic circuit does not have to support any flux created by the conversion. The energy consumption of the load attached to the secondary winding is said to be “reflected” into the primary circuit.

Descriptions of Applications

Devices using soft magnetic materials are used extensively throughout the electronics and power-distribution industries. Selecting the right material and core type for a given application can be difficult and confusing. In this discussion, we will adhere to the differentiation between inductors and transformers and expand upon variations in each of these groups.

Power Transformers. The primary purpose of a power transformer is to convert AC energy from one combination of voltage and current to another and simultaneously provide electrical isolation between the primary and the secondary windings. Power transformers usually have two or more separate windings. The ratio of the number of turns in the primary winding to the number of turns in the secondary winding determines whether the voltage is "stepped up" or "stepped down." Disregarding winding and core losses, total watts input to the primary of the transformer is equal to the watts output from the secondary winding. Quite typically, a power transformer will have more than one secondary winding and the output power is apportioned according to the turns in the individual windings.

The majority of power transformers fall into two categories: **Low-Frequency** power transformers used at frequencies less than 1000 Hertz and **High-Frequency** power transformers used at frequencies above 1000 Hertz. These definitions are not universal, and 1000 Hz was chosen only as an arbitrary reference point. Variations of power transformers include:

Wide (frequency) band transformers.

Impedance matching transformers.

Pulse transformers.

RF Transformers. RF (radio frequency) transformers usually operate at low power levels above 500 KHz. These devices are essentially the same as a power transformer, except that their primary application is to couple AC signals from an output stage of an amplifier to the input of the next stage while electrically decoupling the DC component of the signal. RF transformers are used extensively when coupling the high-potential plate output of a vacuum tube

amplifier to the input grid of the next vacuum tube. This particular application of RF transformers still has some importance in the electronics industry.

Other RF transformers include Baluns transformers, which are used for impedance matching of circuits.

Precision Transformers. Precision transformers are special devices used in "sensing" and instrumentation applications.

One very common type of precision transformer is the **Current Transformer**, or **CT**. CTs usually have one turn of high-current-carrying wire for a primary winding. The secondary high-turn-count winding produces a low-level current proportional to the turns ratio of the windings and to the current in the primary. CTs are used extensively in both the electronics/power-conversion and the power-distribution industries.

Another precision transformer is called the **Flux Gate Magnetometer**. This transformer is used to detect very low-level magnetic fields or very small changes in a magnetic field. These devices have applications in electronic compasses as well as navigation systems. Since flux gate magnetometers can detect the distortion in the earth's magnetic field caused by the presence of armored vehicles and ships, they are used as triggering devices for mines and other types of armament.

A third type of precision transformer is the **Hall Effect Transducer**, which has a gap in the magnetic path of the core in which a Hall effect device is placed. The flux generated in the core by the current in the winding (often just one turn) causes the Hall effect device to produce an output voltage proportional to the flux level.

Saturable Reactors. Saturable reactors are used for voltage and current control and are very effective at high power levels. A special core winding is placed on the saturable reactor, and DC current that passes through this winding will drive the device into and out of magnetic saturation. This, in effect, changes the device's flux transfer ratio, and subsequently the output power of the device is controlled. Large electric industrial furnaces, welders, and high-power voltage regulators commonly use saturable reactors.

A variation of the saturable reactor is called the **MAG AMP**, which operates on the same control-winding concept as the saturable reactor. Mag amps are used as variable series impedance in squarewave and pulse applications, being driven into and out of saturation within a single cycle. One popular application for a mag amp is as a post regulation technique on the output stage of **Switchmode Power Supplies**.

To work effectively, saturable reactors and mag amps require magnetic material with a very square loop to allow for a sharp transition into and out of saturation.

Pure Inductors. Pure inductors are used at all frequencies to provide an electronic circuit with inductive reactance. Such a circuit may be in communications equipment, where the combination of inductive and capacitive reactance is used to tune a stable frequency in an oscillator stage or to provide selective filtering in a band pass filter. Larger pure inductors, called **loading coils**, offset the effects of capacitance built up in long lengths of conductor such as antennae or telephone lines. Pure inductors can be either fixed or variable, depending on their application.

EMI Filters. Electromagnetic interference (EMI) is produced by a multitude of electronic and electrical devices including motors, light dimmers, digital computing devices, switchmode power supplies, and motor speed controls. EMI can be radiated through the air or transmitted through current-carrying conductors. It can interfere with communications, such as radio and television signals, and can affect computer devices that deal with low level high-frequency transmissions.

EMI filters work in a combination of two ways:

EMI filters are designed in conjunction with a capacitor to form a highly efficient—and selective—band pass or band stop filter to impede the unwanted noise.

Lossy EMI filters eliminate noise by converting it to heat (core loss). Lossy filters work well when the noise-component frequency is much higher than the frequency of the desired signal.

An often used type of EMI filter is the **Common Mode Filter**, which is wound with both conductors of the power source in such a way that noise common to both conductors is

filtered. The desired signal passes through the common mode filter unimpeded.

Energy Storage Inductors. Energy storage inductors release the energy stored in them when the voltage across the device is switched. These inductors typically are found, for instance, in the output stage of switchmode power supplies. In this application, the energy storage filter (in conjunction with a filter capacitor) smoothes the ripple current that is superimposed on the DC output of the converter. Usually this filter will also provide some EMI filtering of the inherent noise caused by the high-frequency switching. These devices operate with high amounts of DC current and must maintain a reasonably constant inductance (or core permeability) at high flux levels.

The **Flyback Transformer** is a special type of energy storage device that performs both energy transfer and energy storage functions. It is used in low cost high-frequency power conversion. The type of core used in this device must have moderately high permeability for good flux transfer and, at the same time, high saturation flux density for better energy storage capacity.

Types of Materials and Available Shapes of Cores

Soft Ferrite. Soft ferrites are derived from iron oxide mined from the earth. Metals such as nickel, zinc and manganese are added to the iron oxide. Ferrite material is then pressed and fired to form a crystalline structure that gives ferrite cores their properties. Subsequent grinding or coating operations may take place before the core is used.

Manganese-Zinc soft ferrites typically have high permeability and low eddy current losses; **Nickel-Zinc** ferrites have lower permeabilities with very low eddy current losses. A variety of materials spans the frequency range from 10 KHz to 1 GHz and up. Soft ferrites have low saturation flux densities, in the range of 2500 to 4000 gauss, but are available in shapes that can be readily gapped to handle more MMF at the sacrifice of permeability. Because of their very low core loss at high frequency, ferrites are used extensively in switchmode power supplies as power transformers, filter inductors, current transformers, and mag amps.

Ferrites are available in a wide variety of shapes and sizes with volumes up to about 500 cm. Some other common applications for ferrites are rod antennas, common mode filters, RF transformers, and pure inductors.

Ferrites were plagued for many years by their extremely wide physical and magnetic tolerances. Additionally, ferrites are hindered by rather large temperature dependence. Extensive research and development has improved, but not eliminated, all of the soft ferrite shortcomings. Because of their widespread manufacture and readily available technical information, soft ferrites are the most widely used magnetic material at **High-Frequency**.

Scrapless Laminations and Shearings

Scrapless laminations are usually in the shape of E-E's, U-I's, or E-I's. They are punched from a continuous roll of thin-gauge magnetic material—most commonly silicon-iron, either low grade non-oriented or high-grade oriented types. Nickel-iron or cobalt-iron thin-gauge materials are also available as laminations.

Because of the way they are manufactured, tooling costs are high (the die). For low-quantity requirements, chemical-etch techniques are used to circumvent the tooling costs. Scrapless laminations are taken, one piece at a time, and "stacked" up into a core—generally assembled around the coil. Special stacking machinery is available to facilitate the construction of this type of device. The advantage of scrapless laminations is that, in high-volume applications, it is the least expensive choice for low-frequency high-permeability requirements.

Shearings are widths of thin-gauge strip that are "sheared" to length. Sometimes the shearing is done with a miter, and sometimes "bolt holes" are stamped into each piece. Material is virtually always silicon iron. Shearings are "laid up" into E-I and U-I shapes to form cores for large transformers. The advantage of this type of construction is that it allows fabrication of very large transformers and inductors. The cores in large substation transformers can easily weigh many thousands of pounds.

Silicon-iron scrapless laminations and shearings are the most widely used soft magnetic cores for 60 Hz applications.

Powdered Iron

Powdered iron cores are made from basically 99+% pure iron in the form of extremely small particles. There are many different grades of powdered iron material, ranging from cheap and dirty sponge iron to the fairly expensive carbonyl powders. These materials are purchased in powder form, and the particles are mixed with insulating and binding materials and pressed to finished shape at moderately high pressures. Hard tooling (dies) is required.

Generally the binding agents are cured after the pressing operation, but the cores are not annealed. The intent is that the individual particles **not** fuse or electrically short out. Powdered iron cores are **not** sintered iron parts, a common misconception (see Figure 11).

Because the particles ideally are separated by an air gap (occupied by insulating and bonding material, as well as air), a distributed air gap system is created. Although the raw material used, iron, has a moderately high permeability, the finished powdered iron core has a maximum effective permeability of about 90.

Powdered iron cores can be divided into three permeability categories: high, medium, and low.

The high permeability category, 60 to 90, is used primarily for EMI and energy storage filters. Effective frequency range is up to about 75 KHz.

Medium-permeability powdered iron cores, with permeabilities from 20 to 50, are used as RF transformers, pure inductors, and energy storage inductors. These materials are used at frequencies from 50 KHz to 2 MHz. They can handle higher flux densities and higher power levels without saturating than can their ferrite counterparts. This powdered iron family will become more attractive to switchmode power supply manufacturers as nominal frequencies of operation fall into the range of 250 KHz to 1 MHz.

Applications and Descriptions of Arnold Product Lines (Cont.)

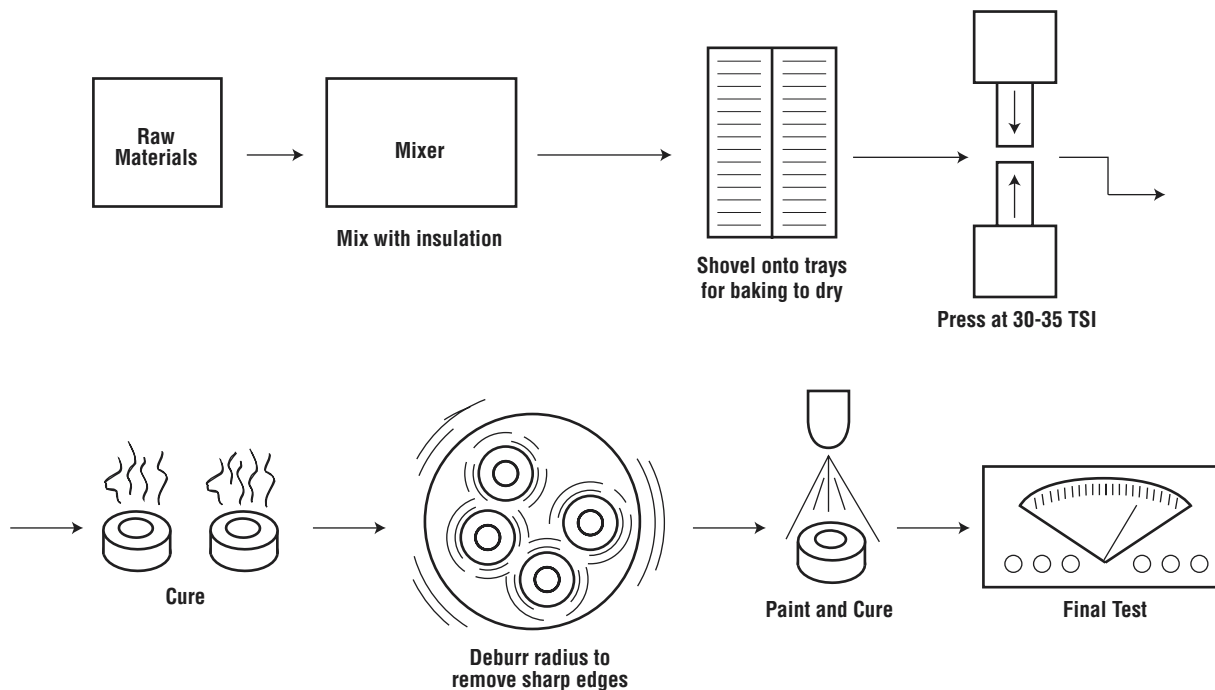

Fig. 11

Low-permeability powdered iron cores, with permeabilities of 7 to 20, are used almost exclusively in the RF range. Typical applications are RF transformers and pure inductors in the frequency range from 2 MHz to 500 MHz. Some radar applications use powdered iron cores at frequencies in excess of 1 GHz. Good flux characteristics combined with low loss and good temperature stability make this type of core material popular for applications in the communications industry.

The versatility of powdered iron pressing techniques allows for many varieties of sizes and shapes. Cores are limited only to the extent of today's metal powder pressing technology. Most powdered iron materials can be ground and lightly machined for special shapes and prototypes.

Because of inexpensive raw materials (iron), powdered iron cores are used frequently in low-cost applications, such as consumer products.

Disadvantages of powdered iron are:

1. limited permeabilities available
2. relatively high core loss
3. permeability varies with AC flux density

Advantages of powdered iron are:

1. low-cost energy storage
2. high energy storage per unit volume
3. temperature stable
4. relatively low-cost tooling
5. available in a variety of shapes

Because powdered iron cores are used for inductors, electrical testing is primarily to determine the effective permeability of the core. Additional testing is occasionally done to determine saturation characteristics (DC bias testing) and core loss properties (Q testing).

MPP

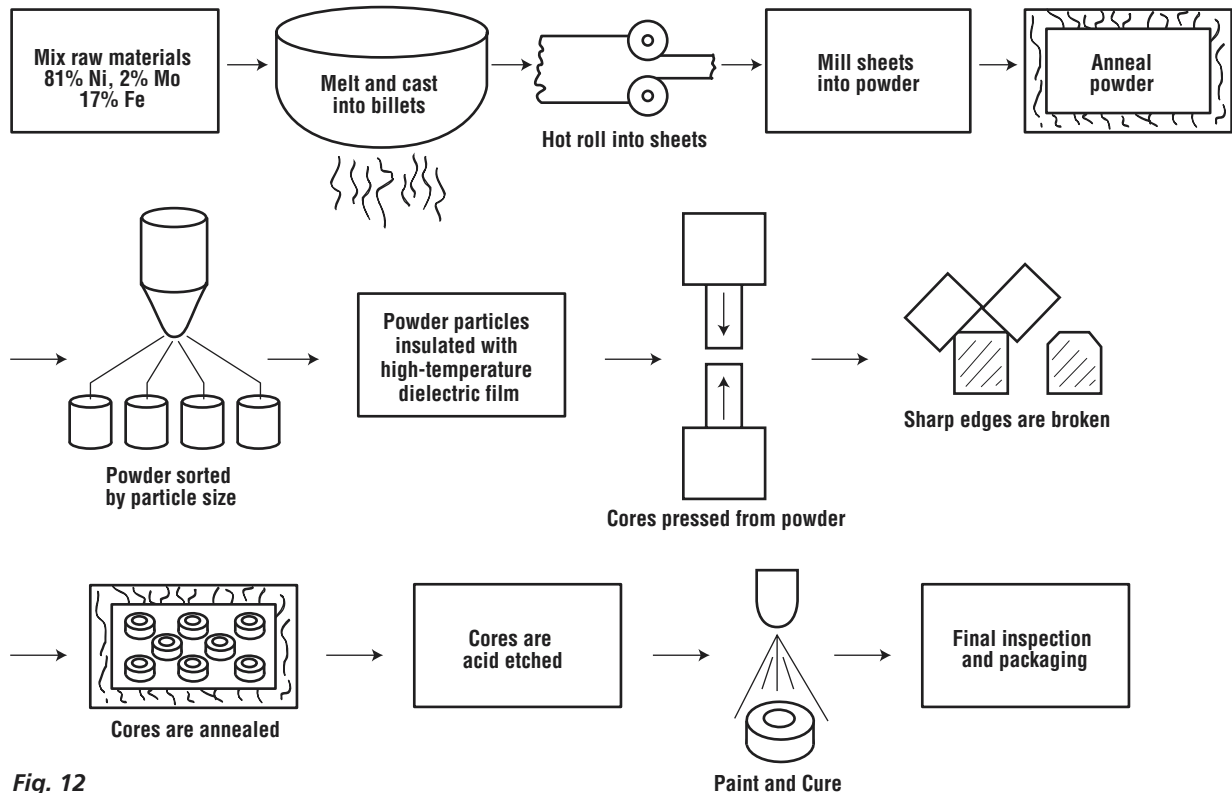

Fig. 12

Another type of powder core manufactured by Arnold is the MPP core, pressed from powder made of 81% nickel, 2% molybdenum and 17% iron. We manufacture our own MPP powder from precisely controlled raw materials that are melted and cast into billets, which are hot-rolled into a brittle sheet. This sheet is then milled into powder form. Insulators are mixed into the MPP powder before pressing into cores at high pressures. MPP cores are stress-relief annealed after pressing (see Figure 12).

The normal effective permeability range for MPP is 14 through 350. In order to obtain such low permeabilities from a material with such an inherently high permeability, a large amount of distributed air gap is added. Because of this large amount of air gap and skewing of the hysteresis loop, MPP cores are extremely stable relative to

flux density, temperature and DC current. They are almost always used for inductors and other energy storage applications.

MPP cores are normally sold pre-graded to a specific permeability tolerance. This feature makes them ideal for pure inductors, because the precise inductance will be known before winding and the number of turns wound onto the core can be adjusted. MPP cores are also widely used for energy storage inductors due to their low inductance swing when DC bias is applied.

The lower-permeability MPP cores can be used at frequencies that exceed 500 KHz. As the permeability of the core increases, stability tends to decrease. The most popular MPP permeabilities are in the 60 to 173 range, where all the advantages of the MPP product are most apparent.

MPP has the advantage of having constant permeability as the flux density varies up to about 3500 gauss. Above that level, permeability does tend to drop off. Other powdered core materials, such as powdered iron, have permeability that varies with flux, adding to the instability of the device.

Disadvantages of MPP:

1. manufacturing cost is higher than that of powdered iron because of the high-performance nickel/iron/molybdenum alloy and high-temperature ceramic-type insulation.
2. very high pressing pressures limit shapes to toroids only

Advantages of MPP:

1. permeability is ultra temperature stable
2. high energy storage per unit volume
3. available graded into small increments of permeability range
4. lowest loss of the powder materials
5. permeability is stable with variations in AC flux density
6. lowest magnetostriction coefficient of the powder core materials

Testing of MPP cores centers on the evaluation of core permeability. One additional step is to "grade" the cores into small increments of permeability. Core-loss, saturation, and temperature response testing are also done routinely.

The applicable catalog for MPP is **Magnetic Powder Cores**.

The part number system is pretty straightforward and usually will be in the format of "A-xxxxyy-2". The "xxx" indicates a more-or-less random number for the dimension/permeability specification for that particular core; and "yyy" is the A_L number, in millihenries per 1000 turns, for the core. The A_L factor, also used in powdered iron and soft ferrite core literature, is simply the inductance that would result from putting the designated number of turns on the core. It takes into account not only the permeability of the core but also the dimensions of it. The units of A_L will be millihenries per 1000 turns or microhenries per 100 turns.

HI-FLUX

HI-FLUX cores are a variation of the standard MPP cores; the composition is 50% nickel and 50% iron instead of 81% Ni / 2% Mo / 17% Fe. The manufacturing procedure is nearly identical to that for MPP. HI-FLUX cores are produced with permeabilities of 14 to 160 in diameters up to 132 mm.

HI-FLUX cores are designed to operate up to about 6500 gauss, as opposed to the 3500-gauss limit of standard MPP. There is some sacrifice in stability because less distributed air gap is required to obtain the reduced permeabilities. Core loss is also higher than MPP. Still, because of their high flux and power-handling capabilities, HI-FLUX cores are used as energy storage inductors and in flyback transformers in SMPS. They are especially well suited for DC and line frequency noise filter inductors (such as the differential-mode choke in a switched mode power supply). Their high saturation flux-density can be used to advantage because core loss is negligible at the low frequencies of these applications.

The cost of HI-FLUX is approximately the same as MPP.

Disadvantages of HI-FLUX:

1. higher core loss than MPP
2. manufacturing cost is higher than that of powdered iron because of the high-performance nickel / iron alloy and high-temperature ceramic-type insulation.
3. very high pressing pressures limit shapes to toroids only

Advantages of HI-FLUX:

1. temperature stability
2. high energy storage per unit volume
3. available graded into small increments of permeability range
4. higher B_{max} than MPP
5. permeabilities up to 160 compared to less than 100 for powdered iron

Electrical testing would be the same as MPP.

Part numbering HI-FLUX cores follows the format of "HF-xxxxyy-2" where "xxx" is a number indicating outside diameter / inside diameter dimension set of the core and "yyy" is the permeability of the material. The applicable catalog is **Magnetic Powder Cores**.

SUPER-MSS

SUPER-MSS is another variation of the basic MPP core. The material is an iron / silicon / aluminum composition manufactured in a manner similar to MPP. The magnetic alloy used in SUPER-MSS is a refined form of "Sendust".

Available permeabilities are 26, 60, 75, 90 and 125. Notable attributes of SUPER-MSS are low loss compared to powdered iron, low cost compared to HI-FLUX and MPP, and a very low magnetostriction coefficient relative to powdered iron. Because of the low magnetostriction, it produces very low mechanical noise levels when excitation is applied, which makes it popular in EMI inductors where low-frequency AC is being filtered. Core loss is higher than that of MPP but less than HI-FLUX and substantially lower than that of powdered iron. Like other powder cores, SUPER-MSS is low in permeability and thus well-suited for energy storage inductor applications.

Because cheaper raw materials are used, SUPER-MSS is less costly than either MPP or HI-FLUX.

Disadvantages of SUPER-MSS are:

1. limited permeabilities available compared to MPP
2. higher core loss than MPP
3. available only in toroids

Advantages of SUPER-MSS are:

1. significantly lower loss compared to powdered iron with little added cost
2. low-cost energy storage
3. high energy storage per unit volume
4. temperature stable
5. low magnetostriction, low noise

Testing would be the same as HI-FLUX.

The applicable catalog is **Magnetic Powder Cores**.

Torodial Tape Cores

As the name implies, this type of core is torodial in shape and is manufactured from "tape." The tape in this case is thin-gauge iron alloy material that has been slit to a predetermined width.

Materials used depend on the desired combination of permeability, saturation flux, core loss, and squareness; they include the following:

1. Deltamax (50% Ni / 50% Fe)
2. 4750 (47% Ni/ 53% Fe)
3. 4-79 Mo-Permalloy (80% Ni / 4% Mo / 16% Fe)
4. Square Permalloy (80% Ni / 4% Mo / 16% Fe)
5. Supermalloy (80 % Ni / 4% Mo / 16% Fe)
6. Supermendur (49% Co / 2% V / 49% Fe)
7. 2V Permendur (49% Co / 2% V / 49% Fe)
8. Square loop iron based amorphous Namglass I
9. Linear iron based amorphous Namglass II
10. Ultra-square loop cobalt based amorphous Namglass III

Manufacturing of tape cores is quite similar, regardless of material type. In all cases, an insulative coating is applied to surfaces of the thin-gauge strip to eliminate layer-to-layer shorting, and the strip is wound spirally around an arbor piece (mandrel) which defines the ID of the toroid. The wound core is then stress-relief annealed.

The anneal for some materials takes place with a DC field applied to the core to enhance the properties of that material. After annealing, the toroid is put into a core "case" with a protective damping medium. Toroidal tape cores are quite strain-sensitive, and the case is necessary to prevent degradation of properties (see Figure 13).

Applications and Descriptions of Arnold Product Lines (Cont.)

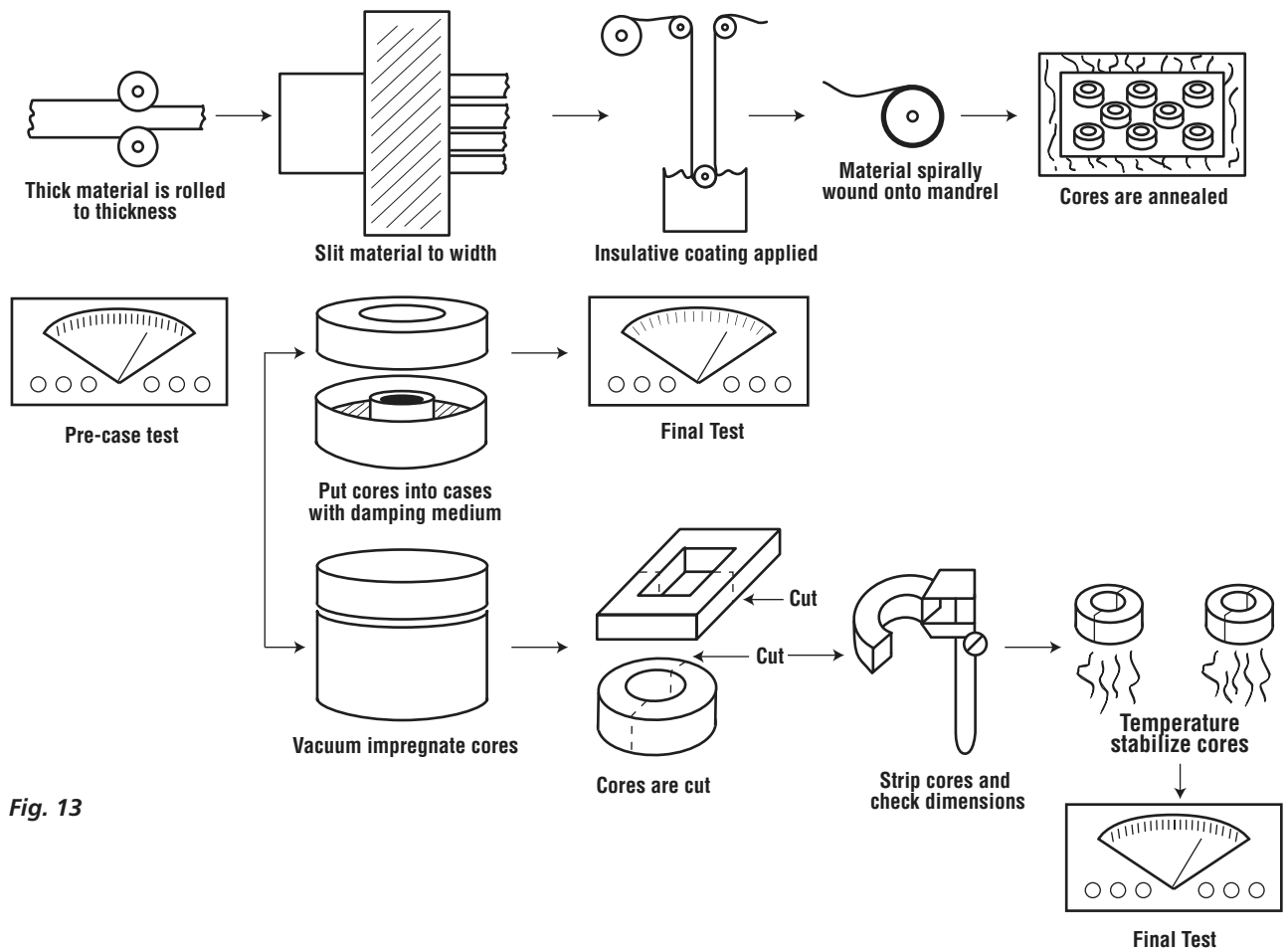

Fig. 13

National-Arnold Magnetics, a Arnold company, is one of the largest producers of tape wound cores.

Description of available materials.

Deltamax is a very square-loop material, meaning that the B_R value is very nearly the same as B_{SAT} . This type of response is desirable in some special-function transformers and inductors such as **MAG AMPS** and **Inverter Transformers**. More on these applications will be covered in later sections.

Raw-material costs are high. Processing Deltamax, as well as all other tape cores, is such that cores are fairly expensive. Applications tend to be military and industrial. Deltamax tape cores are available in 4, 2, 1 and 1/2 mil tape thicknesses.

Disadvantages of Deltamax tape cores are:

1. requires care for maximum properties
2. higher core loss than Permalloy-type material
3. expensive
4. limited frequency response due to core loss

Advantages of Deltamax tape cores are:

1. very square hysteresis loop
2. saturation of about 15000 gauss

Testing of Deltamax tape cores is almost always with the standard CCFR (constant current / flux reset) test. This method measures the dynamic square loop response of the core and permits identification of important material parameters.

4750 is quite similar to Deltamax metallurgically. Instead of having a square hysteresis loop, however, 4750 has a rounded loop with a higher maximum permeability than Deltamax.

4750 is also an expensive material, so applications tend to be more specialized. Low-loss **power transformers** and **current transformers** are two frequent applications of 4750. 4750 tape cores are available in 4, 2, and 1 mil tape thicknesses.

Disadvantages of 4750 tape cores are:

1. requires case for maximum properties
2. higher core loss than Permalloy-type material
3. expensive
4. limited frequency response due to core loss

Advantages of 4750 tape cores are:

1. high permeability
2. saturation of about 15000 gauss

Because cores are utilized for their high permeability, testing centers on that parameter. Initial permeability (measured at low flux densities) is usually specified.

4-79 Mo-Permalloy—more commonly known as Permalloy—is a very-high-permeability, low-core-loss material which normally exhibits a rounded hysteresis loop.

As with the other tape cores, Permalloy most often is used in specialized applications. Current transformers and high-frequency power transformers are typical. 4-79 Permalloy tape cores are available in 4, 2, 1, and 1/2 mil tape thicknesses.

Disadvantages of Permalloy tape cores are:

1. requires case for maximum properties
2. expensive
3. low B_{max} (8000 gauss)

Advantages of Permalloy tape cores are:

1. high permeability
2. low core loss
3. low coercivity

Because cores are utilized for their high permeability, testing centers on that parameter. Initial permeability (measured at low flux densities) usually is specified.

Square Permalloy is a variation of the basic Permalloy-type material for which the anneal has been modified for square-loop response. Although not as square as Deltamax, for instance, it is square enough to operate satisfactorily in magamps and inverter transformers, especially at frequencies up to about 80 KHz (in 1 mil material).

Applications tend to be military and industrial. Square Permalloy tape cores are available in 4, 2, 1, and 1/2 mil tape thickness.

Disadvantages of Square Permalloy tape cores are:

1. requires case for maximum properties
2. expensive
3. limited frequency response due to moderate core loss
4. limited B_{max} (8000 gauss)

Advantages of Square Permalloy tape cores are:

1. square hysteresis loop
2. low core loss

Testing of Square Permalloy tape cores is almost always with the standard CCFR (constant current / flux reset) test. This method measures the dynamic square loop response of the core and permits identification of important material parameters.

Supermalloy is another variation of the high-nickel, Permalloy-type alloy. It is state-of-the-art tape core material, as far as highest permeability is concerned. Applications take advantage of such properties; for instance, current transformers.

As with the other tape cores, Supermalloy is most often used in specialized applications. Typical markets would be military, industrial, and research. Supermalloy tape cores are available in 4, 2, 1, and 1/2 mil tape thickness.

Disadvantages of supermalloy tape cores are:

1. requires case for maximum properties
2. expensive
3. low B_{max} (8000 gauss)

Advantages of Supermalloy tape core are:

1. highest permeability
2. low core loss
3. very low coercivity

Applications and Descriptions of Arnold Product Lines (Cont.)

Because cores are utilized for their high permeability, testing centers on that parameter. Initial permeability (measured at low flux densities) is usually specified.

Supermendur is a cobalt-iron alloy for which the anneal has been modified (includes d.c. stress) for square-loop response. Its most notable characteristic is a B_{max} of 23 to 24 Kgauss. Although not as square as Deltamax, it is square enough to operate satisfactorily in 400 Hz magamps and inverter transformers. Because it generally is available only in 4 mil tape thickness, frequencies usually are limited to 400 Hz.

Applications are almost always military in nature.

Disadvantages of Supermendur tape cores are:

1. requires case for maximum properties
2. very expensive
3. limited frequency response due to high core loss
4. 4 mil tape only

Advantages of Supermendur tape cores are:

1. square hysteresis loop
2. highest B_{max}

Testing of Supermendur toroidal tape cores is almost always with the standard CCFR (constant current / flux reset) test. This method measures the dynamic square loop response of the core and permits identification of important material parameters.

2V Permendur is basically the same alloy as Supermendur. Instead of a square hysteresis loop, however, 2V Permendur has a rounded loop with a higher maximum permeability than Supermendur. B_{max} is slightly lower at 21 to 22 Kgauss, 2V Permendur is notable for its very high magnetostriction coefficient.

Applications usually are military or industrial. 2V Permendur tape cores are available in 4 and 2 mil tape thickness.

Disadvantages of 2V Permendur tape cores are:

1. requires case for maximum properties
2. higher cores loss than Permalloy-type material
3. very expensive
4. limited frequency response due to high core loss

Advantages of 2V Permendur tape cores are:

1. high magnetostriction
2. saturation of about 21000 gauss

Because cores are utilized for their high permeability, testing centers on that parameter. Initial permeability (measured at low flux densities) is usually specified. 2V Permendur also is tested for B_{max} and occasionally for core loss.

Namglass I is one of the so-called amorphous alloys. Raw material is purchased 1 mil thick and slit to the proper width. None of the amorphous materials can be rolled down to thinner thicknesses. Namglass I is a moderately square-loop material that finds use in specialized transformers such as **Pulse Transformers**.

Raw material costs are quite high, so markets tend to be in more-specialized industrial areas, such as medical applications.

Disadvantages of Namglass I tape cores are:

1. requires case for maximum properties
2. higher core loss than permalloy-type material
3. very expensive
4. limited frequency response due to core loss

Advantages of Namglass I tape cores are:

1. low magnetostriction
2. saturation of about 14000 gauss
3. high volume resistivity

Namglass I is tested for B_{max} and for core loss.

Namglass II is another amorphous alloy, similar in composition to Namglass I. Namglass II is a linear permeability material that finds use in specialized transformers such as **Pulse Transformers** and also in **Common-Mode Inductors**.

Disadvantages of Namglass II tape cores are:

1. requires case for maximum properties
2. very expensive
3. moderate permeability (approx. 5000)

Advantages of Namglass II tapes cores are:

1. low magnetostriction
2. saturation of about 14000 gauss
3. high volume resistivity
4. low high-frequency core loss

Namglass II is tested for B_{max} for core loss, and for permeability.

Namglass III is another amorphous alloy. Namglass III is an ultra-square-loop material that finds use, almost exclusively, in high-frequency magamps. Its metallurgical composition is quite different from the other two amorphous materials, in that Namglass III contains cobalt.

Namglass III is finding ever-increasing application in industrial and military power-supply designs.

Disadvantages of Namglass III tape cores are:

1. requires case for maximum properties
2. very expensive
3. low B_{max} (approx. 5500)

Advantages of Namglass III tape cores are:

1. lowest magnetostriction
2. ultra-square-loop response
3. highest-volume resistivity
4. lowest high-frequency core loss
5. lowest coercivity

Namglass III toroidal tape cores are evaluated with the standard CCFR (constant current / flux reset) test. This method measures the dynamic square-loop response of the core and permits identification of important material parameters. Occasionally, Namglass III is also tested for core loss.

Cut Tape Cores

The term "tape core" can refer not only to the conventional toroid but also to C and E-Cores made of tape-core materials. The practice is justified because the cores are wound and annealed in the same place as the toroidal versions.

The magnetic materials are the same as for toroids with the exception of amorphous material, which is not available in cut core form at this time. The manufacturing procedure is similar but, instead of being cased, the cores are

impregnated with epoxy and cut in half. Three-phase cores also are produced—something that would be physically impossible with a toroid. Because of this flexibility, there is almost no limit to the size that a cut core can be manufactured. On tape-core materials, however, there is a maximum strip width of 2.00" on thin-gauge material. (see Figure 13).

Cut cores do not have cases like tape cores; they are impregnated for mechanical rigidity. However, epoxy impregnation of tape-wound cores tends to re-stress the fragile material, reducing permeability and increasing core loss. As a rule, the performance of the cut tape cores will be significantly worse than the cased toroid. The amount of degradation is not always predictable, but can be of the order of 30% more core loss and half the permeability. The tradeoffs are that cut cores are much easier to wind and additional air gap can be added to the core. This last point means that this type of core can be used not only for transformers but also for inductors. The cut tape core generally is considered a high-performance alternative to the Silectron C-Core.

One thing cut tape cores do have in common with toroidal versions is the cost factor: Both are expensive. Applications tend to be more exotic and specialized in nature.

Disadvantages of cut tape cores are:

1. expensive
2. higher core loss than toroid
3. lower permeability than toroid
4. hard to make large cores of thinner tape

Advantages of cut tape cores are:

1. can insert discrete air gap
2. can wind with foils and large-diameter wire
3. easier to wind than toroids
4. lower core loss than Silectron C-Cores
5. Supermendur cut cores allow highest energy capacity

Testing of cut tape cores is primarily to evaluate them for core loss and exciting losses. Occasionally B_{max} will be evaluated.

Because of high material costs and high labor content, bobbin cores tend to be extremely expensive on a per-pound basis.

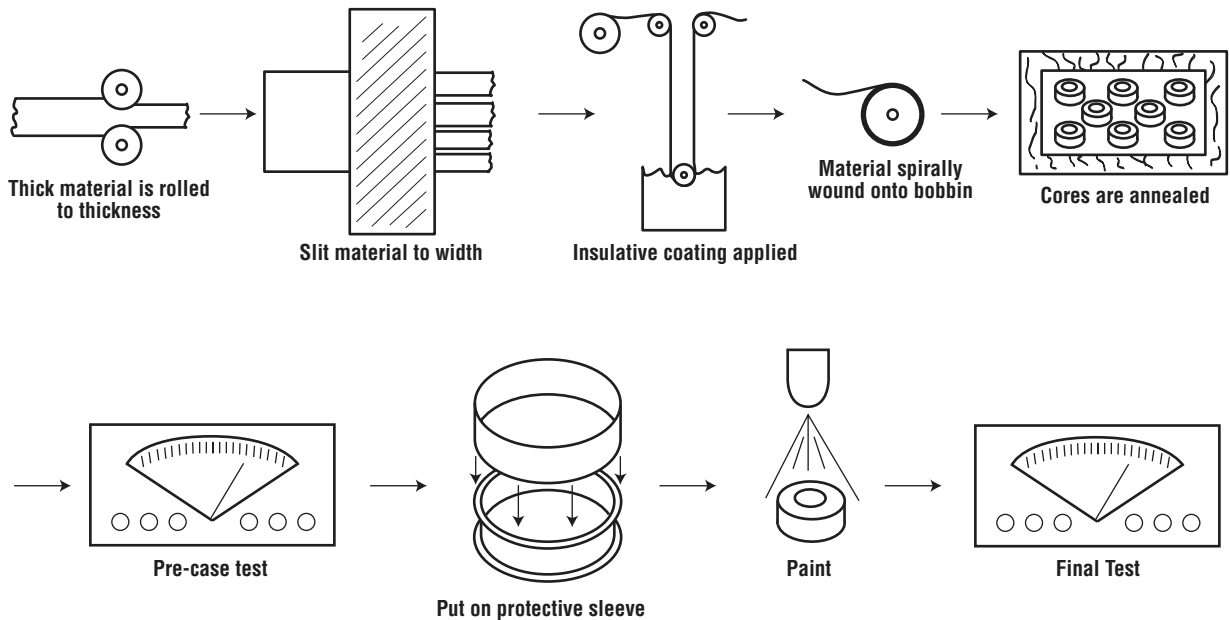

Fig. 14

Bobbin Tape Wound Cores

A special variant of tape core, the bobbin core is similar to the standard toroid tape core except that, because build-ups of ultra-thin tape generally are quite small, the material is wound on a stainless steel bobbin. Strips used in standard tape-wound toroids are limited to 1/2 mil thickness, but bobbin cores can be manufactured from tape as thin as 1/8 mil. Manufacturing is similar to the standard toroidal tape core, except that the bobbin defines the ID of the core instead of mandrel. Materials commonly used are Deltamax and Permalloy (see Figure 14).

Bobbin cores are characterized by very high permeability at low flux levels, square loop response, and very low coercivity. They originally were conceived for "core memory" applications. Needless to say, this industry is all but extinct and what is left utilizes soft ferrites. The most popular application today is in various **Magnetometer** designs. This would include compasses, fusing devices for armament, sonobuoys, etc. All of these utilize the very high permeability of the core material. Another growing application for bobbin cores is as inverter transformers in small, board-mount DC-DC converters.

Disadvantages of bobbin cores are:

1. expensive
2. poor use of space due to presence of bobbin
3. bobbin must be machined to size
4. difficult to manufacture

Advantages of bobbin cores are:

1. can wind in ultra-thin tape
2. can be made with very small OD/ID/HT
3. very high permeability
4. impervious to shock because tape is attached to bobbin

Testing of bobbin cores normally follows a special pulse test sequence that was designed around the "core memory" application. It is somewhat similar to a CCFR test and does an adequate job of revealing important parameters. Some bobbin core customers provide highly specialized test fixtures that perform application-oriented testing on the cores they purchase.

Silectron Toroids

Silectron is a grain-oriented, 3.25% Si / 96% Fe alloy. One popular core configuration made of this material is the toroid, not unlike the toroidal tape core. Manufacturing of Silectron toroids is virtually identical to that of toroid tape cores. This type of core is available in a core case, like tape cores, and with epoxy impregnation or epoxy impregnation/epoxy coating. As with cut tape cores, the impregnation process does degrade the properties of the material.

Silectron has a moderately high permeability and high flux density. Applications for Silectron toroids are current transformers, low-frequency power transformers, and low-frequency magamps. Silectron toroids are available in 11, 9, 4, 2, and 1 mil tape thicknesses.

Because of Silectron's high flux density and low cost, applications are more general in nature than nickel-iron, cobalt-iron, or amorphous toroids.

Disadvantages of Silectron toroids are:

1. higher core loss than tape core
2. difficult to wind due to toroidal shape

Advantages of Silectron toroids are:

1. relatively inexpensive
2. high B_{max}

Testing of Silectron is almost always for cores loss and exciting loss. Occasionally, B_{max} or BH loop testing is conducted.

Silectron C and E-cores

Cut cores made of Silectron are manufactured identically to cut tape cores. The type of insulation used on the tape and the method of anneal may differ but, for the most part, the process is the same. One major difference is that Silectron is not stymied by the 2.00" restriction on tape width.

Like uncut Silectron cores, Silectron C-Cores have moderately high permeability. Without added air gap, they find use in low-frequency power transformers and pulse transformers. With air gap added, they are used in inductor applications. The only limitation to its use is core loss.

Silectron is a low-cost material, and applications cover the full spectrum of the marketplace.

Disadvantages of Silectron C-Cores are:

1. high core loss
2. moderate permeability material
3. air gap lowers permeability

Advantages of Silectron C-Cores are:

1. available in three-phase form
2. coil is easy to wind
3. coil can utilize foils and heavy-gauge wire
4. can insert varying amounts of air gap
5. inexpensive
6. high flux capacity

Testing of Silectron C-Cores is predominately centered on core loss and exciting losses. 1 and 2 mil C-Cores are routinely tested for pulse permeability, but this also reveals information about core loss and exciting energy. Special permeability testing, similar to that performed on powder cores is done occasionally.

Distributed Gap Cores

DG (distributed gap, sometimes called "take apart") cores are a special variation of the Silectron C-Core. It is similar in shape to a C-Core, but the air gap is "distributed" over a portion of the magnetic length. Winding is accomplished by a special winding machine. The core is not impregnated, and it is assembled onto the coil by the customer. Anneal is the same as other Silectron cores. Only thicker material (9 to 12 mil) is utilized.

This type of core is used almost exclusively for 60 Hz distribution transformers.

Testing is to determine core loss and exciting losses.

Industry Applications of Arnold Core Products

In general, the choice of magnetic material is the result of a trade-off between saturation flux density, energy loss and cost.

As a rule, Arnold core products can be used as either transformers or inductors.

Keep in mind the distinction between inductors (energy storage) and transformers (energy transfer) as you review the following analysis showing specific usage.

Low-frequency power conversion would include the following specific applications, which could turn up in any number of industries. What is actually being described is an electrical function, not a job-specific device.

Distribution power transformers

Silectron C and E-Cores
Silectron toroids
Supermendur C and E-Cores (400 HZ)
DG cores

Welding Transformers

Silectron C-Cores

Rectifier Transformers

Silectron C and E-Cores
Supermendur C and E-Cores

Mag Amps and Saturable Reactors

Silectron C-Cores
Silectron toroids
Supermendur toroid tape cores
Deltamax toroid tape cores
Square Permalloy toroid tape cores

Pulse transformers

Silectron C-Cores
Permalloy, Supermalloy, Deltamax, and Supermendur cut cores
Permalloy, Supermalloy, Deltamax, Namglass I, Namglass II, and Supermendur toroid tape cores
Silectron toroids

Instrumentation (current and potential transformers)

Silectron C-Cores

Silectron toroids

Permalloy, Supermalloy, and Deltamax cut cores
Permalloy, Supermalloy, Namglass I, and Namglass II toroid tape cores
MPP, SUPER-MSS, HI-FLUX

Power Inductors

Silectron C-Cores
Permalloy, Supermalloy, and Deltamax cut cores
MPP, SUPER-MSS, HI-FLUX

EMI Inductors

Silectron C-Cores
Permalloy, Supermalloy, and Deltamax cut cores
Namglass I and Namglass II toroid tape cores
MPP, SUPER-MSS, HI-FLUX

High-frequency applications for which Arnold products can be used would be as follows.

D.C. Filters

MPP, SUPER-MSS, HI-FLUX
Silectron C-Cores
Permalloy, Supermalloy, and Deltamax cut cores

A.C. Filters

MPP, SUPER-MSS, HI-FLUX
Permalloy, Supermalloy, and Deltamax cut cores

High Q Filters

MPP

Mag Amp and Saturable Reactor

Square Permalloy and Namglass III toroid tape core

Power transformers

Namglass II, Permalloy, and Supermalloy toroid tape cores
Permalloy, Supermalloy, and Deltamax cut cores
Bobbin cores

Flyback Transformers

MPP, HI-FLUX and SUPER-MSS

Industry Applications of Arnold Core Products (Cont.)

Instrumentation (current transformers, magnetometers)

- Permalloy and Supermalloy toroid tape core
- Permalloy Bobbins cores

Looking at major industry groups and typical applications, the list would be as follows.

Computer

- High-frequency power conversion
 - High-frequency applications
- Low-frequency power conversion
 - All listed in Low-Frequency power conversion except for welding transformers, pulse transformers, and instrumentation magnetics
- Special Silectron structures
 - High-performance laminated motor parts

Automotive

- High frequency
 - Permalloy bobbin cores for magnetometers used in compasses.
 - MPP, HI-FLUX, SUPER-MSS and Silectron for magnetics used in special ignition systems
- Low frequency
 - Welding transformers
- Special Silectron structures for fuel-injection systems

Motor speed control/Light dimmer

- C-Cores for EMI and A.C. filters
- SUPER-MSS for EMI and A.C. filters
- Silectron toroids for current transformers
- Toroid tape cores for current transformers
- SUPER-MSS for current transformers
- Silectron toroids for mag amps
- Toroid tape cores for mag amps

Instrumentation

- Silectron toroids with gaps for hall effect current sense
- Toroid tape cores with gaps for hall effect current sense
- Permalloy bobbins cores for magnetometers
- Silectron toroids for current transformers
- Toroid tape cores for current transformers

- MPP, HI-FLUX, SUPER-MSS for D.C./A.C. filters
- Silectron C-Cores for current transformers

Electrical utility hardware

- DG cores for distribution transformers
- Silectron C-cores used for power factor adjusting inductors
- Silectron C-Cores and toroids for current transformers and for potential transformers

Medical equipment

- C-cores for HV transformers
- C-cores for EMI filters
- MPP, HI-FLUX and SUPER-MSS for EMI Filters
- High-frequency power conversion.
 - See High-Frequency Applications
- C-Cores for high-efficiency 60 HZ power transformers

Welding and other metal processing

- C-Cores for high frequency induction furnaces
- C-Cores for step-down welding transformers
- Silectron toroids for current transformers
- Silectron toroids for mag amp control
- Toroid tape for current transformers
- Toroid tape core for mag amp control

Telecommunications

- MPP for loading coils
- High-frequency power conversion.
 - See High-Frequency Applications
- Low-frequency power conversion.
 - See Low-Frequency conversion

Military hardware

- High-frequency power conversion.
 - See High-Frequency Applications
- Low-frequency power conversion.
 - See Low-Frequency conversion

Lighting and Plasma Displays

- High-frequency power conversion.
 - See High-Frequency Applications
- Low-frequency power conversion.
 - See Low-Frequency conversion

Appendix Recommended Application Chart

MATERIAL	TYPICAL FREQUENCY RANGE	TEMP. RANGE °C	SIZE/SHAPE LIMITATIONS	POWER CAPACITY	COST	ADVANTAGES/ (DISADVANTAGES)
POWER TRANSFORMERS						
Ferrites						
Power Ferrites	10kHz–2 MHz	-55 to 150	E's, toroids, Pot Cores. Limited to 500 cm ³	Low	Low	High Perm, Low Loss at High Hz (Low Saturation Flux)
High Freq Ferrites	50kHz–1GHz	-55 to 150	E's, toroids, Pot Cores. Limited to 250 cm ³	Low	Medium	Good perm, Loss at High Hz (Low Saturation Flux)
MPP, HI-FLUX, SUPER-MSS						
MPP	5kHz–200 kHz	-55 to 200	Toroids up to 132 mm	Medium	High	Very Stable (Low Perm usually limits transformer applications to flyback types.)
HI-FLUX	5kHz–50 kHz	-55 to 200	Toroids up to 132 mm	Medium	High	Very Stable, High Saturation (Low Perm usually limits transformer applications to flyback types.)
SUPER-MSS	5 kHz–200 kHz	-55 to 200	Toroids up to 132 mm	Medium	Medium	Very Stable, High Saturation (Low Perm usually limits transformer applications to flyback types.)
Powdered Iron						
High Perm	NR	NR	NR	NR	NR	(High Loss, Low Perm)
Medium Perm	25 kHz–1MHz	-55 to 155	Unlimited to 350 cm ³	Medium	Low	Low Loss, Good Stability (Low Perm)
Low Perm	1MHz–1 GHz	-55 to 155	Unlimited to 350 cm ³	Medium	Low	Low Loss, Good Stability (Low Perm)
Tape Cores						
Ni-Fe	50 Hz–100kHz	-55 to 200	Toroids Unlimited Size	High	High	Highest Perm, Square Loop, High Saturation (High Cost, Toroids)
Si-Fe	50 Hz–10 kHz	-55 to 350	Toroids Unlimited Size	Very High	Medium	High Perm, High Saturation Flux (Core Loss, Toroids Only)
Co-Fe	50 Hz–1 kHz	-55 to 450	Toroids Unlimited Size	Very High	Very High	Highest Saturation Flux (High Cost, 4 mil only, Toroids only)
Amorphous	50 Hz–500 kHz	-55 to 175	Toroids to 130 mm	High	High	Low Loss, High Saturation Flux (High Cost, Toroids Only)

Appendix Recommended Application Chart (Cont.)

MATERIAL	TYPICAL FREQUENCY RANGE	TEMP. RANGE °C	SIZE/SHAPE LIMITATIONS	POWER CAPACITY	COST	ADVANTAGES/ (DISADVANTAGES)
POWER TRANSFORMERS (Cont.)						
Cut Cores						
Si-Fe	50 Hz–10 kHz	-55 to 175	Toroids, E's & U's Unlimited Size	Very High	High	Good Perm, High Saturation Flux (Core Loss, Air Gap Effects)
Ni-Fe	50 Hz–100 kHz	-55 to 175	Toroids, E's & U's Unlimited Size	High	High	High Perm, High Saturation Flux (High Cost, Air Gap Effects)
Co-Fe	50 Hz–1 kHz	-55 to 175	Toroids, E's & U's Unlimited Size	Very High	Very High	Highest Saturation Flux (Highest Cost, Air Gap Effects)
Bobbin Core						
Ni-Fe	5 kHz–1 MHz	-55 to 200	Small Toroids	Low	High	Low Loss, High Perm (Small Size, Toroids)
Dist. Gap						
Si-Fe	50–60 Hz	-55 to 200	Single Phase, Three	Very High	Low	High Perm, Small Air Gap (Low Frequency Only, Si-Fe Only)
Scrapless Lams and Shearings						
Si-Fe, Co-Fe, and Ni-Fe	50–60 Hz	-55 to 200	Single Phase, Three Phase, Unlimited Size	Very High	Low	High Perm, Small Air Gap Unlimited Size (Low Frequency Only, Si-Fe Only)
RF TRANSFORMERS						
Ferrites						
Power Ferrites	1 MHz–5 MHz	-55 to 150	Mostly Cyl, Pot Cores. Other small Shapes	Low	Low	High Perm, Tunable, High Q (Poor Stability, Mu Tolerance)
High Freq Ferrites	1 MHz–1 GHz	-55 to 150	Toroids Pot Cores Small Shapes	Low	Medium	Good perm, Tunable High Q at High Frequency
MPP, HI-FLUX, SUPER-MSS						
MPP	1 MHz–2 MHz	-55 to 200	Toroids up to 132 mm	Low	High	Very Stable (Low Perm, Lower Q than Ferrite)
HI-FLUX	NR	NR	NR	NR	NR	(High Loss)
SUPER-MSS	NR	NR	NR	NR	NR	
Powdered Iron						
High Perm	NR	NR	NR	NR	NR	(High Loss)
Medium Perm	1 MHz–10 MHz	-55 to 155	Unlimited to 350 cm ³	Medium	Medium	Good Stability
Low Perm	10 MHz–500 MHz	-55 to 155	Unlimited to 350 cm ³	Medium	Medium	Low Loss, Good Stability (Low Perm)

Appendix Recommended Application Chart (Cont.)

MATERIAL	TYPICAL FREQUENCY RANGE	TEMP. RANGE °C	SIZE/SHAPE LIMITATIONS	POWER CAPACITY	COST	ADVANTAGES/ (DISADVANTAGES)
RF TRANSFORMERS (Cont.)						
Tape Cores						
Ni-Fe	1 MHz–2 MHz	-55 to 200	Toroids Unlimited Size	High	High	High Perm (Good Q at Low Flux Only, High Cost, Toroids Only)
Si-Fe	NR	NR	NR	NR	NR	(High Loss)
Co-Fe	NR	NR	NR	NR	NR	(High Loss)
Amorphous	1 MHz–2 MHz	-55 to 175	Toroids to 130 mm	High	High	Low Loss, High Saturation Flux (High Cost, Toroids Only)
Cut Cores						
Si-Fe	NR	NR	NR	NR	NR	(High Loss)
Ni-Fe	NR	NR	NR	NR	NR	(High Loss)
Co-Fe	NR	NR	NR	NR	NR	(High Loss)
Bobbin Core						
Ni-Fe	1 MHz–5 MHz	-55 to 200	Small Toroids	Low	High	Low Loss, High Perm (Small Size Low Flux for High Q)
Dist. Gap						
Si-Fe	NR	NR	NR	NR	NR	(High Loss)
Scrapless Lams and Shearings						
Si-Fe, Co-Fe, and Ni-Fe	NR	NR	NR	NR	NR	(High Loss)
PRECISION TRANSFORMERS						
Ferrites						
Power Ferrites	10 kHz–5 MHz	-55 to 150	E's, toroids, Pot Cores. Limited to 500 cm ³	Medium	Low	Good Perm, Low Loss at High Frequency (Low Saturation Flux)
High Freq	NR	NR	NR	NR	NR	(Low Perm)
MPP, HI-FLUX, SUPER-MSS						
MPP	DC–500 kHz	-55 to 200	Toroids up to 132 mm.	Very Low	High	Low Perm is useful in sensing applications where high frequency, small-signals are superposed on high-current conductors.
HI-FLUX	NR	NR	NR	NR	NR	(Low Perm)
SUPER-MSS	NR	NR	NR	NR	NR	(Low Perm)

Appendix Recommended Application Chart (Cont.)

MATERIAL	TYPICAL FREQUENCY RANGE	TEMP. RANGE °C	SIZE/SHAPE LIMITATIONS	POWER CAPACITY	COST	ADVANTAGES/ (DISADVANTAGES)
PRECISION TRANSFORMERS (Cont.)						
Powdered Iron						
High Perm	NR	NR	NR	NR	NR	(Low Perm)
Medium Perm	NR	NR	NR	NR	NR	(Low Perm)
Low Perm	NR	NR	NR	NR	NR	(Low Perm)
Tape Cores						
Ni-Fe	to approx 10 MHz	-55 to 200	Toroids Unlimited Size	High	High	Highest Perm, Best Accuracy, High Sat. (High Cost, Toroids)
Si-Fe	50 Hz–10 kHz	-55 to 350	Toroids Unlimited Size	Very High	Low	Good Perm, High Saturation Flux (Core Loss, Toroids Only)
Co-Fe	50 Hz–1 kHz	-55 to 450	Toroids Unlimited Size	Very High	Very High	Highest Saturation Flux, Magnetostrictive (High Cost, Losses)
Amorphous	50 Hz–2 MHz	-55 to 175	Toroids Unlimited Size	High	Very	Low Loss, High Saturation Flux (High Cost, Toroids Only)
Cut Cores						
Si-Fe	50 Hz–10 kHz	-55 to 175	Toroids, E's & U's Unlimited Size	Very High	Low	Good Perm, High Saturation Flux (Core Loss, Air Gap Effects)
Ni-Fe	50 Hz–100 kHz	-55 to 175	Toroids, E's & U's Unlimited Size	High	High	High Perm, High Saturation Flux (High Cost, Air Gap Effects)
Co-Fe	50 Hz–1 kHz	-55 to 175	Toroids, E's & U's Unlimited Size	Very High	Very High	Highest Saturation Flux (Highest Cost, Air Gap Effects)
Bobbins Core						
Ni-Fe	to 2 MHz	-55 to 200	Small Toroids	Low	High	Low Loss, High Perm, Ultra thin Tapes (Small Size, Toroids Only)
Dist. Gap						
Si-Fe	50–60 Hz	-55 to 200	Single Phase, Three Phase	Very High	Low	High Perm, Small Air Gap (Low Frequency Only, Si-Fe Only)
Scrapless Lam and Shearing						
Si-Fe, Co-Fe, and Ni-Fe	50–60Hz	-55 to 200	Single Phase, Three Phase, Unlimited Size	Very High	Low	High Perm, Small Air Gap, Unlimited Size (Low Frequency Only, 9-12 mil Si-Fe Only)

Appendix Recommended Application Chart (Cont.)

MATERIAL	TYPICAL FREQUENCY RANGE	TEMP. RANGE °C	SIZE/SHAPE LIMITATIONS	POWER CAPACITY	COST	ADVANTAGES/ (DISADVANTAGES)
SATURABLE REACTORS						
Ferrites						
Power Ferrites	10kHz–2 MHz	-55 to 150	E's, toroids, Pot Cores. Limited to 500 cm ³	Low	Low	Good Perm, Low Core Loss (Low Saturation Flux, High Hysteresis)
High Freq Ferrites	NR	NR	NR	NR	NR	(Low Perm)
MPP, HI-FLUX, SUPER-MSS						
MPP	NR	NR	NR	NR	NR	(Low Perm)
HI-FLUX	NR	NR	NR	NR	NR	(Low Perm)
SUPER-MSS	NR	NR	NR	NR	NR	(Low Perm)
Powdered Iron						
High Perm	NR	NR	NR	NR	NR	(Low Perm)
Medium Perm	NR	NR	NR	NR	NR	(Low Perm)
Low Perm	NR	NR	NR	NR	NR	(Low Perm)
Tape Cores						
Ni-Fe	50 Hz–100 kHz	-55 to 200	Toroids Unlimited Size	High	High	Highest Perm, Square Loop, High Saturation (High Cost, Toroids)
Si-Fe	50 Hz–10 kHz	-55 to 350	Toroids Unlimited Size	Very High	Medium	Good Perm, High Saturation Flux, Good Squareness (Core Loss)
Co-Fe	50 Hz–1 kHz	-55 to 450	Toroids Unlimited Size	Very High	Very High	Highest Saturation Flux, Square Loop (High Cost, 4 mil Only)
Amorphous	50 Hz–2 kHz	-55 to 175	Toroids to 130 mm	High	High	Low Loss, Ultra Square Loop (High Cost, Toroids Only)
Cut Cores						
Si-Fe	50 Hz–10 kHz	-55 to 175	Toroids, E's & U's Unlimited Size	Very High	Low	Good Perm, High Saturation Flux (Core Loss, Air Gap Effects)
Ni-Fe	50 Hz–100 kHz	-55 to 175	Toroids, E's & U's Unlimited Size	High	High	High Perm, High Saturation Flux (High Cost, Air Gap Effects)
Co-Fe	50 Hz–1 kHz	-55 to 175	Toroids, E's & U's Unlimited Size	Very High	Very High	Very High Saturation Flux (Highest Cost, Air Gap Effects)
Bobbin Core						
Ni-Fe	5 kHz–2 MHz	-55 to 200	Small Toroids	Low	High	Low Loss, High Perm, Very Square (Small Size, Toroids)

Appendix Recommended Application Chart (Cont.)

MATERIAL	TYPICAL FREQUENCY RANGE	TEMP. RANGE °C	SIZE/SHAPE LIMITATIONS	POWER CAPACITY	COST	ADVANTAGES/ (DISADVANTAGES)
SATURABLE REACTORS (Cont.)						
Dist. Gap						
Si-Fe	50–60 Hz	-55 to 200	Single Phase, Three Phase	Very High	Low	High Perm, Small Air Gap (Low Frequency Only, Thick mil Only)
Scrapless Lams and Shearings						
Si-Fe, Co-Fe, and Ni-Fe	50–60 Hz	-55 to 200	Single Phase, Three Phase, Unlimited Size	Very High	Low	High Perm, Small Air Gap, Unlimited Size (Low Frequency Only, Thick mil Si-Fe Only)
PURE INDUCTORS						
Ferrites						
Power Ferrites	10 kHz–5 MHz	-55 to 150	E's, toroids, Pot Cores. Limited to 500 cm ³	Low	Low	High Perm, Low Loss, Tunable (Low Saturation Flux, Poor Stability)
High Freq Ferrites	50kHz–1 GHz	-55 to 150	E's, toroids, Pot Cores. Limited to 250 cm ³	Medium	Medium	Good perm, Low Loss, Tunable (Low Saturation, Poor Stability)
MPP, HI-FLUX, SUPER-MSS						
MPP	DC-300 kHz	-55 to 200	Toroids up to 132 mm	High	High	Very Stable, High Saturation, Low Magnetostriction, Lowest Loss of Powder Materials
HI-FLUX	DC-100 kHz	-55 to 200	Toroids up to 132 mm	Very High	High	Very Stable, Higher Saturation than MPP or Super-MSS
SUPER-MSS	DC-300 kHz	-55 to 200	Toroids up to 132 mm	High	Medium	Very Stable, High Saturation, Low Magnetostriction, Low Loss
Powdered Iron						
High Perm	1 kHz–50 kHz	-55 to 175	Toroids up to 132 mm	High	Low	High Saturation, Low Cost (Core Loss, Low Perm)
Medium Perm	50 kHz–2 MHz	-55 to 155	Unlimited to 350 cm ³	High	Low	Low Loss, Good Stability (Low Perm)
Low Perm	1 MHz–500 MHz	-55 to 155	Unlimited to 350 cm ³	High	Medium	Low Loss, Good Stability (Low Perm)
Tape Cores						
Ni-Fe	50 Hz–500 kHz	-55 to 200	Toroids Unlimited Size	Low	High	Highest Perm, High Saturation (High Cost, Low Energy)
Si-Fe	50 Hz–10 kHz	-55 to 350	Toroids Unlimited Size	Low	Medium	High Perm, High Saturation Flux (Core Loss, Low Energy)
Co-Fe	50 Hz–1 kHz	-55 to 450	Toroids Unlimited Size	Low	Very High	Highest Saturation Flux (High Cost, 4 mil Only, Low Energy)
Amorphous	50 Hz–500 kHz	-55 to 175	Toroids to 130 mm	Low	High	Low Loss, High Saturation Flux (High Cost, Low Energy)

Appendix Recommended Application Chart (Cont.)

MATERIAL	TYPICAL FREQUENCY RANGE	TEMP. RANGE °C	SIZE/SHAPE LIMITATIONS	POWER CAPACITY	COST	ADVANTAGES/ (DISADVANTAGES)
PURE INDUCTORS (Cont.)						
Cut Cores						
Si-Fe	50 Hz–10 kHz	-55 to 175	Toroids, E's & U's Unlimited Size	Very High	Medium	Good Perm, High Saturation Flux (Core Loss)
Ni-Fe	50 Hz–100 kHz	-55 to 175	Toroids, E's & U's Unlimited Size	High	High	High Perm, High Saturation Flux (High Cost)
Co-Fe	50 Hz–1 kHz	-55 to 175	Toroids, E's & U's Unlimited Size	Very High	Very High	Highest Saturation Flux (Highest Cost)
Bobbin Core						
Ni-Fe	5 kHz–1 MHz	-55 to 200	Small Toroids	Very Low	High	Low Loss, High Perm (Small Size, Toroids)
Dist. Gap						
Si-Fe	50–60 Hz	-55 to 200	Single Phase, Three Phase	Low	Low	High Perm, Small Air Gap (Low Frequency Only, Thick mil Only)
Scrapless Lams and Shearings						
Si-Fe, Co-Fe, and Ni-Fe	50–60 Hz	-55 to 200	Single Phase, Three Phase, Unlimited Size	Very High	Low	High Perm, Small Air Gap, Unlimited Size (Low Frequency Only, Thick mil Si-Fe Only)
EMI FILTERS						
Ferrites						
Power Ferrites	10 kHz–5 MHz	-55 to 150	E's, toroids, Pot Cores. Limited to 500 cm ³	Low	Low	High Perm, Low Loss (Low Saturation Flux, Poor Stability)
High Freq Ferrites	50 kHz–1 GHz	-55 to 150	E's, toroids, Pot Cores. Limited to 250 cm ³	Medium	Medium	Good perm, Low Loss (Low Saturation Flux, Poor Stability)
MPP, HI-FLUX, SUPER-MSS						
MPP	DC-1 MHz	-55 to 200	Toroids up to 132 mm	High	High	Very Stable, High Saturation, Low Magnetostriction, Wide Range of Permeability
HI-FLUX	DC-300 kHz	-55 to 200	Toroids up to 132 mm	Very High	High	Very Stable, Higher Saturation than MPP or Super-MSS
SUPER-MSS	DC-1 MHz	-55 to 200	Toroids up to 132 mm	High	Medium	Very Stable, High Saturation, Low Magnetostriction

Appendix Recommended Application Chart (Cont.)

MATERIAL	TYPICAL FREQUENCY RANGE	TEMP. RANGE °C	SIZE/SHAPE LIMITATIONS	POWER CAPACITY	COST	ADVANTAGES/ (DISADVANTAGES)
EMI FILTERS (Cont.)						
Powdered Iron						
High Perm	50 kHz–500 kHz	-55 to 175	Toroids up to 132 mm	High	Low	High Saturation, Low Cost (Core Loss)
Medium Perm	50 kHz–2 MHz	-55 to 155	Unlimited to 350 cm ³	High	Low	Low Loss, Good Stability (Low Perm)
Low Perm	2 MHz–500 MHz	-55 to 155	Unlimited to 350 cm ³	High	Medium	Low Loss, Good Stability (Low Perm)
Tape Cores						
Ni-Fe	50 Hz–2 MHz	-55 to 200	Toroids Unlimited Size	Low	High	Highest Perm, High Saturation (High Cost, Low Energy)
Si-Fe	50 Hz–10kHz	-55 to 350	Toroids Unlimited Size	Low	Medium	High Perm, High Saturation Flux (Core Loss, Low Energy)
Co-Fe	50 Hz–1 kHz	-55 to 450	Toroids Unlimited Size	Low	Very High	Highest Saturation Flux (High Cost, 4 mil Only, Low Energy)
Amorphous	50 Hz–2 MHz	-55 to 175	Toroids Unlimited Size	Low	High	Low Loss, High Saturation Flux (High Cost, Low Energy)
Cut Cores						
Si-Fe	50 Hz–10 kHz	-55 to 175	Toroids, E's & U's Unlimited Size	Very High	Medium	Good Perm, High Saturation Flux (Core Loss, Requires Air Gap)
Ni-Fe	50 Hz–250 kHz	-55 to 175	Toroids, E's & U's Unlimited Size	High	High	High Perm, High Saturation Flux (High Cost, Requires Air Gap)
Co-Fe	50 Hz–1 kHz	-55 to 175	Toroids, E's & U's Unlimited Size	Very High	Very High	Highest Saturation Flux (Highest Cost, Requires Air Gap)
Bobbin Cores						
Ni-Fe	5 kHz–1 MHz	-55 to 200	Small Toroids	Very Low	High	Low Loss, High Perm (Small Size, Low Energy)
Dist. Gap						
Si-Fe	50–60 Hz	-55 to 200	Single Phase, Three Phase	Medium	Low	High Perm, Small Air Gap (Low Frequency Only, Thick mil Only)
Scrapless Lams and Shearings						
Si-Fe, Co-Fe, and Ni-Fe	50–60 Hz	-55 to 200	Single Phase, Three Phase, Unlimited Size	Very High	Low	High Perm, Unlimited Size (Low Frequency Only, Thick mil Si-Fe Only, Requires Air Gap)

Appendix Recommended Application Chart (Cont.)

MATERIAL	TYPICAL FREQUENCY RANGE	TEMP. RANGE °C	SIZE/SHAPE LIMITATIONS	POWER CAPACITY	COST	ADVANTAGES/ (DISADVANTAGES)
ENERGY STORAGE INDUCTORS						
Ferrites						
Power Ferrites	10 kHz–500 kHz	-55 to 150	E's, toroids, Pot Cores. Limited to 500 cm ³	Medium	Low	High Perm, Low Loss, Tunable (Low Saturation, Requires Gap)
High Freq Ferrites	50 kHz–500 MHz	-55 to 150	E's, toroids, Pot Cores. Limited to 250 cm ³	Medium	Medium	Good perm, Low Loss, Tunable (Low Saturation, Poor Stability)
MPP, HI-FLUX, SUPER-MSS						
MPP	DC-300 kHz	-55 to 200	Toroids up to 132 mm	High	High	Very Stable, High Saturation, Low Magnetostriction, Lowest Loss of Powder Materials
HI-FLUX	DC-100 kHz	-55 to 200	Toroids up to 132 mm	Very High	High	Very Stable, Higher Saturation than MPP or Super-MSS
SUPER-MSS	DC-300 kHz	-55 to 200	Toroids up to 132 mm	High	Medium	Very Stable, High Saturation, Low Magnetostriction, Low Loss
Powdered Iron						
High Perm	1 kHz–100 kHz	-55 to 175	Toroids up to 132 mm	High	Low	High Saturation, Low Cost (Core Loss)
Medium Perm	50 kHz–2 MHz	-55 to 155	Unlimited to 350 cm ³	High	Low	Low Loss, Good Stability (Low Perm)
Low Perm	1 MHz–500 MHz	-55 to 155	Unlimited to 350 cm ³	High	Medium	Low Loss, Good Stability (Low Perm)
Tape Cores						
Ni-Fe	NR	NR	NR	NR	NR	(High Perm)
Si-Fe	NR	NR	NR	NR	NR	(High Perm)
Co-Fe	NR	NR	NR	NR	NR	(High Perm)
Amorphous	NR	NR	NR	NR	NR	(High Perm)
Cut Cores						
Si-Fe	50 Hz–100 kHz	-55 to 175	Toroids, E's & U's Unlimited Size	Very High	Medium	Good Perm, High Saturation Flux (Core Loss, Requires Air Gap)
Ni-Fe	50 Hz–250 kHz	-55 to 175	Toroids, E's & U's Unlimited Size	High	High	High Perm, High Saturation Flux (High Cost, Requires Air Gap)
Co-Fe	50 Hz–1 kHz	-55 to 175	Toroids, E's & U's Unlimited Size	Very High	Very High	Highest Saturation Flux (Highest Cost, Requires Air Gap)
Bobbin Core						
Ni-Fe	NR	NR	NR	NR	NR	(High Perm)
Dist. Gap						
Si-Fe	NR	NR	NR	NR	NR	(High Perm)
Scrapless Lams and Shearings						
Si-Fe, Co-Fe, and Ni-Fe	50–60 Hz	-55 to 200	Single Phase, Three Phase, Unlimited Size	Very High	Low	High Perm, Unlimited Size (Low Frequency Only, Requires Air Gap)

We hope you have found the information contained in this document to be useful and we encourage you to share your comments and questions with us. We promise to read all the mail sent to us and respond.

Please note that we assume no responsibility for reviewing unsolicited information or ideas for our business and will not be liable as a result of the disclosure of such information or any similarities that may appear in future Arnold information or publications. Please do not reveal any trade secrets or other confidential information in your messages to us.

The email address for the website staff is contactus@arnoldengr.com. Mail may be sent to: Arnold Web site, 300 N. West Street, Marengo, IL 60152, USA. Our fax number is (+1) 815-568-2247.

Disclaimer of Liability

Arnold, The Arnold Engineering Company, SPS Technologies, Inc. and their affiliated companies (collectively "Arnold") make no representations about the suitability of the information, including implied warranties of merchantability and fitness for a particular purpose, title and non-infringement. In no event will Arnold be liable for any errors contained herein for any special, indirect, incidental or consequential damages or any other damages whatsoever in connection with the furnishing, performance or use of such information. The information and documents available herein is subject to revision or change without notice.

Disclaimer of Endorsement

Reference herein to any specific commercial product, process, or service by trade name, trademark, manufacturer, or otherwise, does not constitute or imply its endorsement, recommendation, or favoring by Arnold, The Arnold Engineering Company or its parent or affiliated companies. The information herein shall not be used for advertising or product endorsement purposes without the express written consent of Arnold.

Copyright Notice

Copyright 2003 The Arnold Engineering Company. All rights reserved.

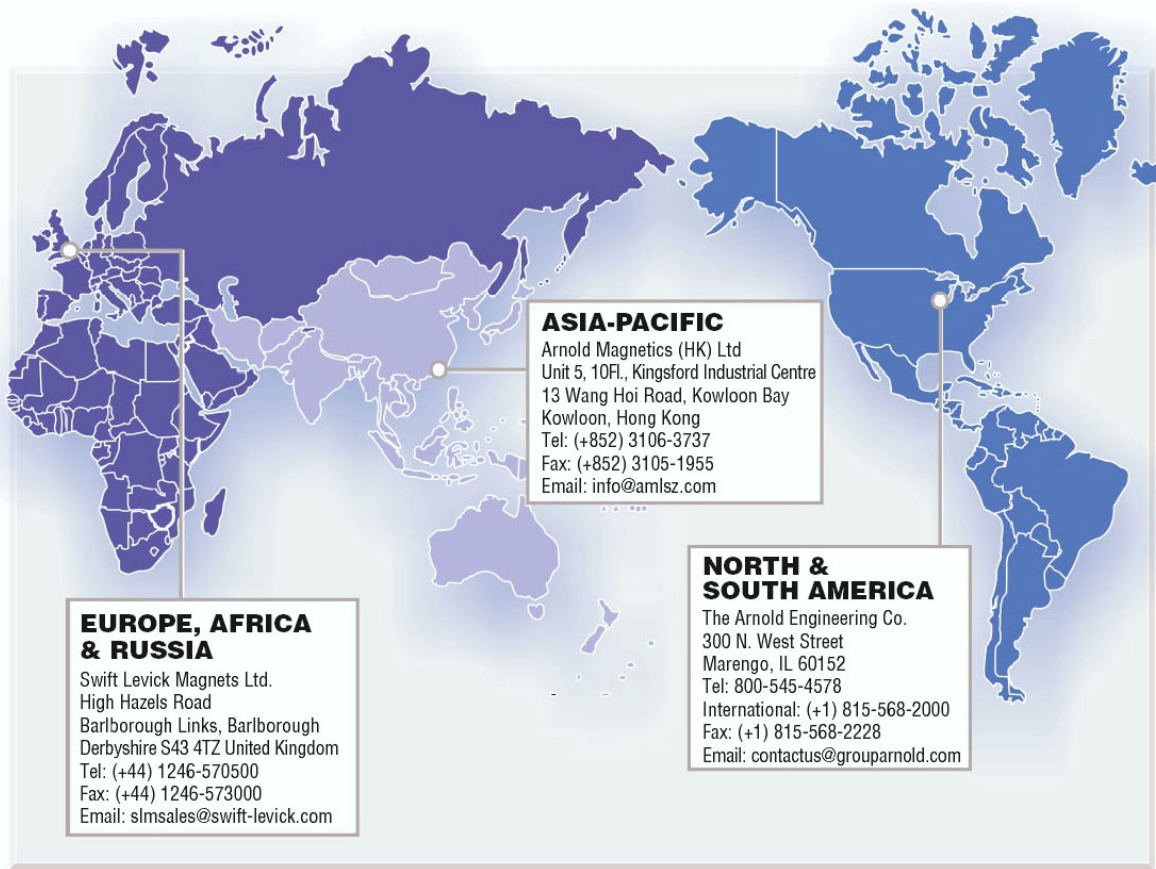

ARNOLD[®]

THE MAGNETIC PRODUCTS GROUP OF **SPS**
TECHNOLOGIES

770 Linden Avenue
Rochester, NY 14625-2764

585-385-9010 • Fax: 585-385-5625
contactus@arnoldmagnetics.com